

PARTS CATALOGUE/TECHNICAL GUIDE

Cal. V656A

PARTS CATALOGUE



Cal. V656A

[SPECIFICATIONS]

Item		Cal. No.	V656A
Movement			 <p>(x 1.0)</p>
Movement size	Outside diameter		ø29.5mm 26.0mm between 3 o'clock and 9 o'clock sides
	Casing diameter		ø28.8mm
	Height		3.1mm
Time indication			<ul style="list-style-type: none"> • Three hands (Hour, minute and second) • Chronograph hands (Minute, second and 1/10 second) • 24-hour hand
Driving system			Step motor (4 pcs.)
Additional mechanism			<ul style="list-style-type: none"> • Stopwatch function <ul style="list-style-type: none"> • Measures up to 60 minutes in 1/10 second increments • Split time measurement • Train wheel setting device • Electric circuit reset switch • Demonstration movement of the hands
Loss/gain			Monthly rate at normal temperature range: less than 20 seconds
Regulation system			Nil
Measuring gate by quartz tester			Any gate can be used
Battery			SEIKO SR920SW, Maxell SR920SW, Sony SR920SW, Eveready 371, Matsushita SR920SW Battery life is approximately 2 years. Voltage: 1.55V
Jewels			0 jewel

Disassembling procedures Figs. : ① → ⑤①
 Reassembling procedures Figs. : ⑤① → ①

Lubricating: Types of oil Oil quantity

 Moebius A  Normal quantity
 Moebius V

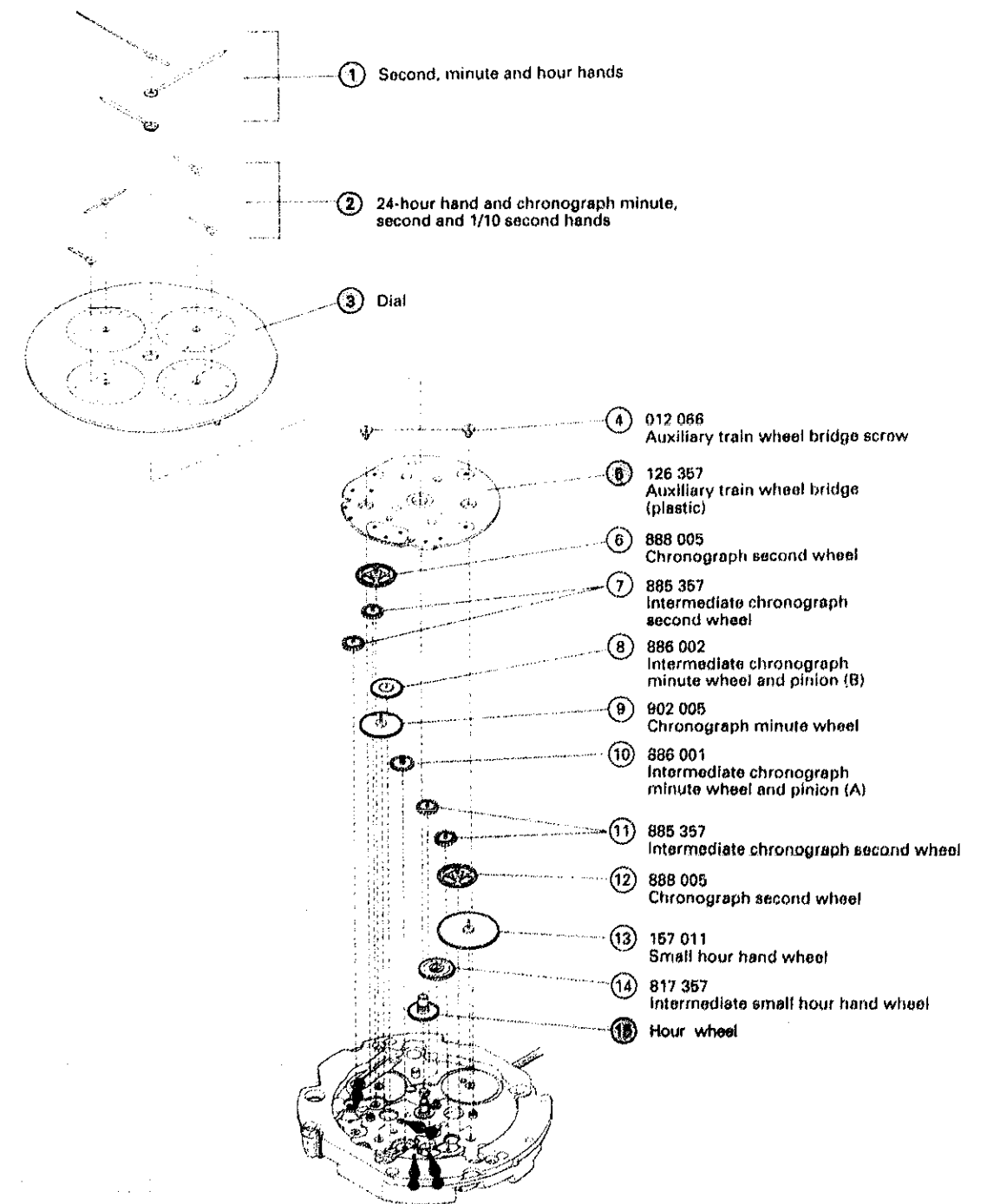

  Please see the remarks on the following pages.

PARTS CATALOGUE

Cal. V656A

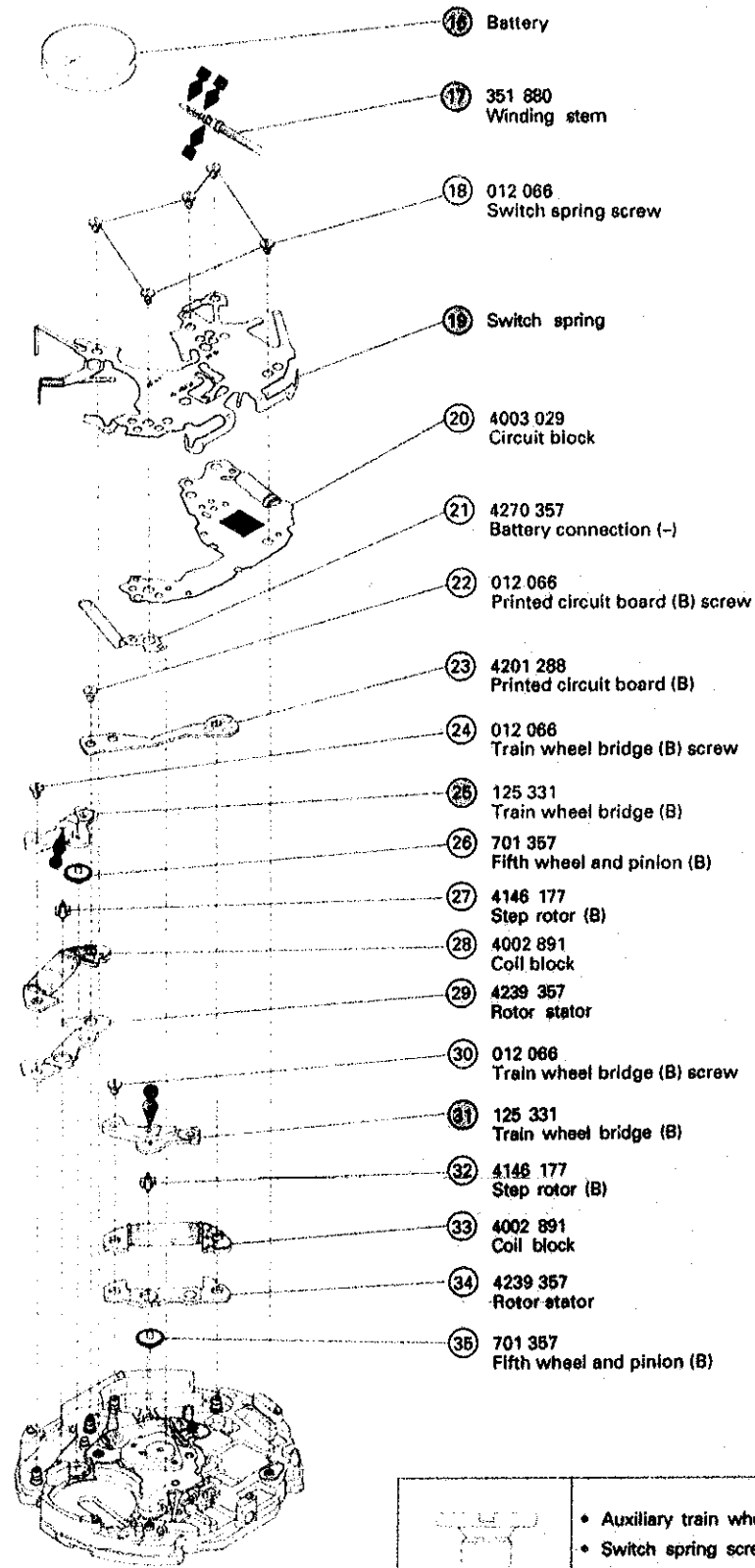

- 16 Battery
- 17 351 880
Winding stem
- 18 012 066
Switch spring screw
- 19 Switch spring
- 20 4003 029
Circuit block
- 21 4270 357
Battery connection (-)
- 22 012 066
Printed circuit board (B) screw
- 23 4201 288
Printed circuit board (B)
- 24 012 066
Train wheel bridge (B) screw
- 25 125 331
Train wheel bridge (B)
- 26 701 357
Fifth wheel and pinion (B)
- 27 4146 177
Step rotor (B)
- 28 4002 891
Coil block
- 29 4239 357
Rotor stator
- 30 012 066
Train wheel bridge (B) screw
- 31 125 331
Train wheel bridge (B)
- 32 4146 177
Step rotor (B)
- 33 4002 891
Coil block
- 34 4239 357
Rotor stator
- 35 701 357
Fifth wheel and pinion (B)

	• Auxiliary train wheel bridge screw (2 pcs.)
	• Switch spring screw (5 pcs.)
	• Train wheel bridge (B) screw (2 pcs.)
	• Printed circuit board (B) screw (1 pc.)

012 066

 Please see the remarks on the following pages.

PARTS CATALOGUE

Cal. V656A

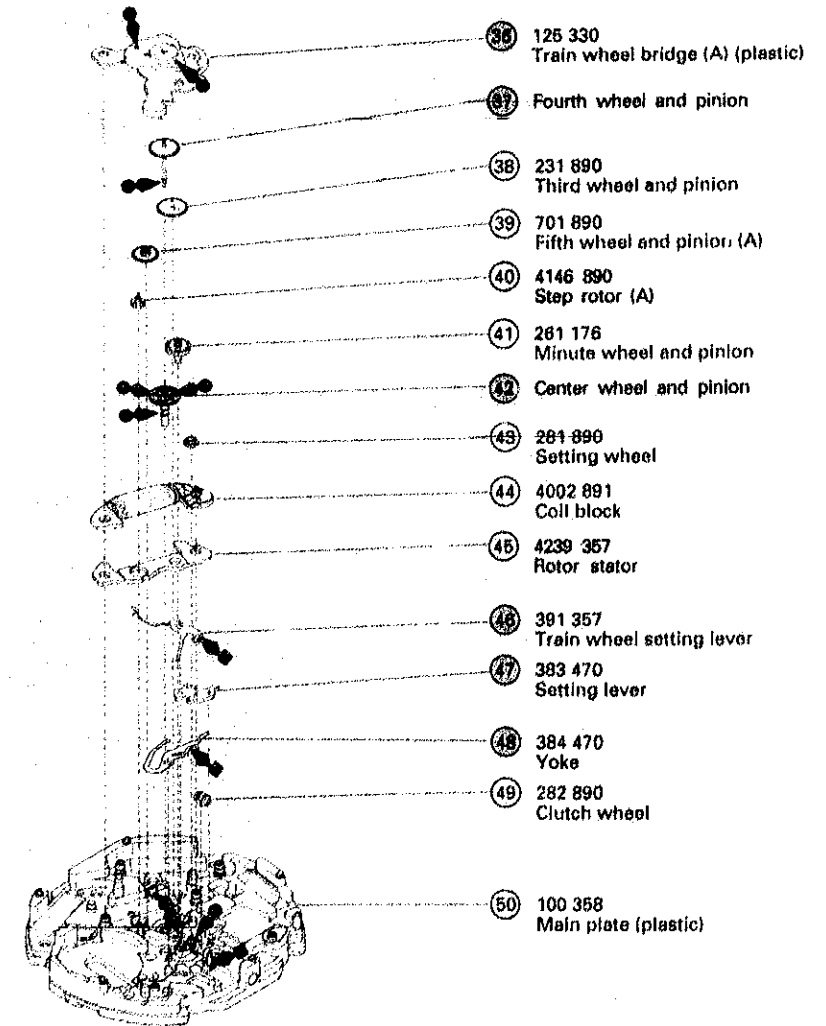

- 36 125 330
Train wheel bridge (A) (plastic)
- 37 Fourth wheel and pinion
- 38 231 890
Third wheel and pinion
- 39 701 890
Fifth wheel and pinion (A)
- 40 4146 890
Step rotor (A)
- 41 261 176
Minute wheel and pinion
- 42 Center wheel and pinion
- 43 261 890
Setting wheel
- 44 4002 891
Coil block
- 45 4239 357
Rotor stator
- 46 391 357
Train wheel setting lever
- 47 383 470
Setting lever
- 48 384 470
Yoke
- 49 282 890
Clutch wheel
- 50 100 358
Main plate (plastic)

 Please see the remarks on the following pages.

PARTS CATALOGUE

Cal. V656A

Remarks:

- ⑮ Hour wheel
- ⑳ Fourth wheel and pinion
- ㉑ Center wheel and pinion



Those parts specified above are determined based on the design of cases. Check the case number and refer to "CASING PARTS CATALOGUE" to choose a corresponding one.

• Discrimination of the hands installation height

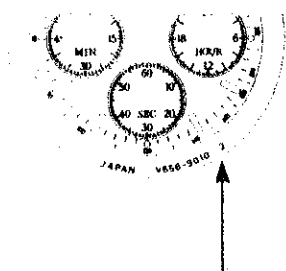
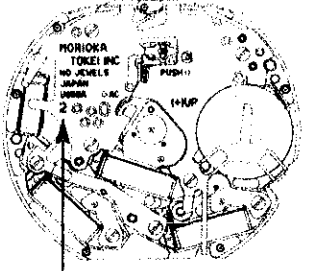
Cal. V656A watch has numerals printed on the dial and movement to indicate the hands installation height. When repairing, refer to the table below.

Discrimination	Standard type	
	Height	Numeral for discrimination
		2
Printed on	Dial	Movement
Printed position	Ex.) Standard type  The numeral is printed on the extreme right.	Ex.) Standard type  The numeral is printed below the calibre number.

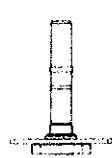
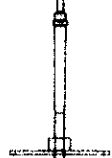
* Hands installation height can be discerned from the shape of the following parts. Refer to the table below.

Numeral for discrimination	Center wheel and pinion	Fourth wheel and pinion	Hour wheel
2	 221 357	 241 406	 271 406

- ⑰ Winding stem 351 880

The type of winding stem is determined based on the design of cases. Check the case number and refer to "CASING PARTS CATALOGUE" to choose a corresponding winding stem.

- ⑲ Switch spring

4245 358: Use with the movement bearing the discrimination numeral "2".

TECHNICAL GUIDE

Cal. V656A

- The explanation here is only for the particular points of Cal. V656A.
- For the repairing, checking and measuring procedures, refer to the "TECHNICAL GUIDE, GENERAL INSTRUCTIONS".

I. STRUCTURE OF THE CIRCUIT BLOCK

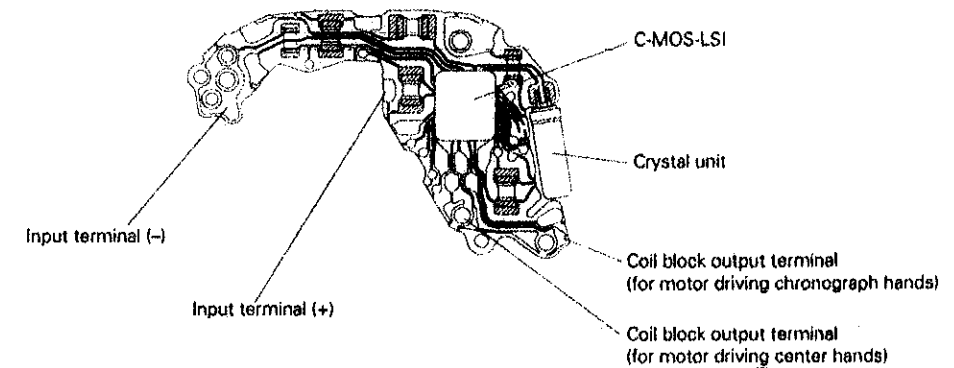

II. REMARKS ON INSTALLING THE BATTERY

- After the battery is replaced with a new one, or after the battery is re-installed following repairing procedures, be sure to short-circuit the AC terminal of the circuit block and the battery connection (+) with conductive tweezers to reset the circuit as shown in the illustration below. (When checking the current consumption, short-circuit with power supplied from an external source.)

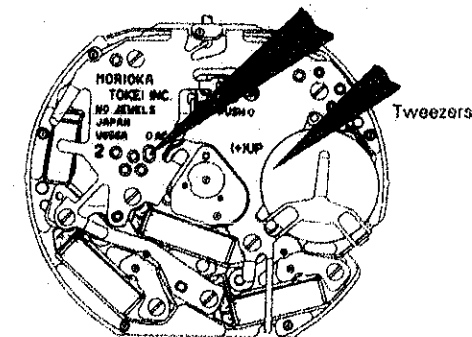

- The circuit can be reset with the complete watch. Follow the procedure below.

1. Pull out the crown.
2. Press buttons "A" and "B" at the same time for approximately 2 seconds.
 - * The chronograph second hand makes half a revolution counterclockwise and then returns to where it was. The chronograph 1/10 second hand makes a full revolution clockwise and stops.

TECHNICAL GUIDE

Cal. V656A

3. Press button "A" repeatedly to reset the chronograph 1/10 second hand to the "0" position. Press button "B" repeatedly to reset the chronograph second and minute hands to the "0" position.
 - * The "0" position of the chronograph 1/10 second hand differs depending on the models. (Some models have the "0" position of the chronograph 1/10 second hand at 3 and 9 o'clock sides of the small dial. In that case, check that the hand is level with its ends pointing to those "0" positions.)
 - * The chronograph minute hand moves correspondingly with the chronograph second hand.
 - * The hands move quickly if the respective buttons are kept pressed.
4. Turn the crown to set the desired time and push the crown back in to the normal position.

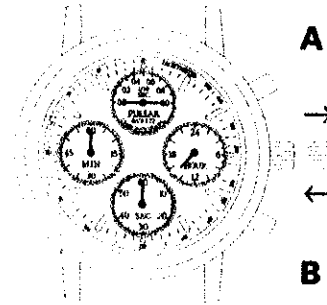

III. REMARKS ON DISASSEMBLING AND REASSEMBLING

Use the universal movement holder for disassembling and reassembling.

- ① Hour, minute and second hands
- ② 24-hour hand and chronograph minute, second and 1/10 second hands

Since a plastic main plate is used, place the movements on a flat metal plate or the like, and then install the hands at the position as specified below. Before doing so, check that the battery is installed in the movement.

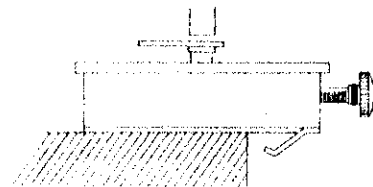

Hands to be installed	Positions at which hands are installed
Hour, minute and second hands	12 o'clock position
Chronograph minute, second and 1/10 second hands	"0" position*
24-hour position	24 o'clock position

* The "0" position of the chronograph 1/10 second hand differs depending on the models. Some models have the "0" position of the chronograph 1/10 second hand at 3 and 9 sides of the small dial. In that case, install the hand so that the both ends of the hand point to those "0" positions.

- ③ Dial
Pry up the dial at the two recessed portions indicated in the illustration using a screwdriver.

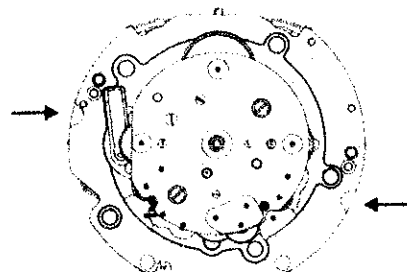

TECHNICAL GUIDE

Cal. V656A

- ⑤ Auxiliary train wheel bridge

• Setting position

- ⑧ 886 002 Intermediate chronograph minute wheel and pinion (B)

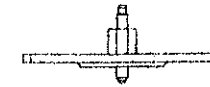

- ⑨ 902 005 Chronograph minute wheel

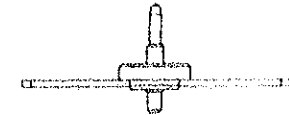

- ⑩ 886 001 Intermediate chronograph minute wheel and pinion (A)

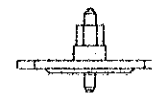

- ⑮ 271 406 Hour wheel



- ⑦ ⑪ 885 357 Intermediate chronograph second wheel



- ⑭ 817 357 Intermediate small hour hand wheel



- ⑥ ⑫ 888 005 Chronograph second wheel

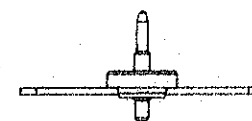

- ⑬ 157 011 Small hour hand wheel



TECHNICAL GUIDE

Cal. V656A

16 Battery

• How to remove

Using with tweezers, catch the protrusion of the switch spring indicated in the illustration below, and detach the hooking portion from the main plate. Then, remove the battery.

• How to install

Slip the battery sideways into the gap under the battery clamp of the switch spring. Then push the battery clamp so that the hooking portion catches the main plate securely.

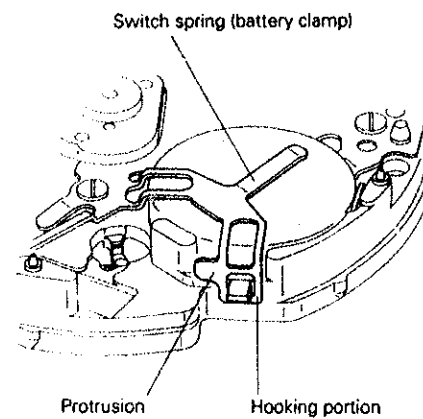

17 Winding stem

• How to remove

Remove the winding stem with the crown at the normal position while pushing the setting lever (marked with "⇩ PUSH").

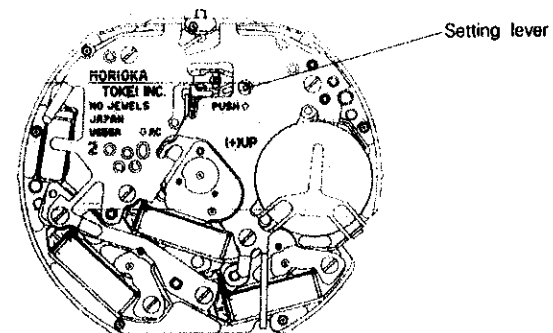

TECHNICAL GUIDE

Cal. V656A

36 Train wheel bridge (A)

25 31 Train wheel bridge (B)

• Setting position

[Plan]

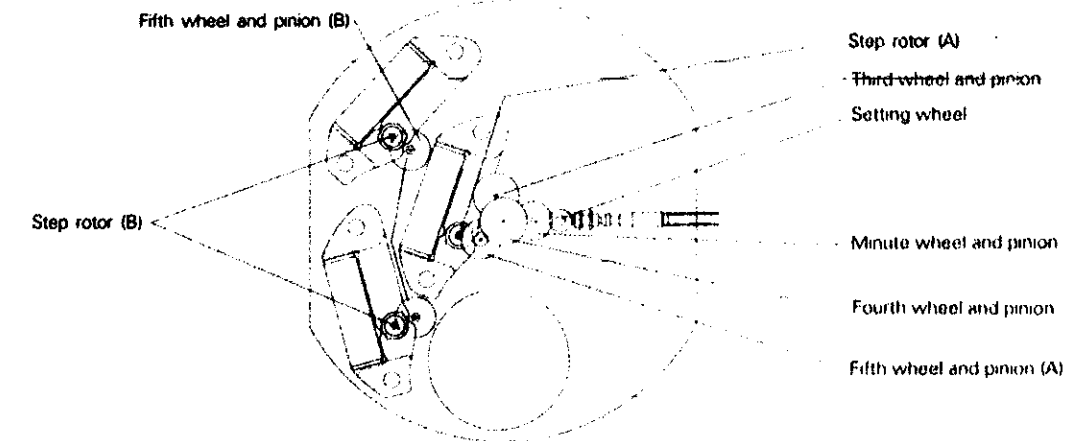

[Cross section]

Train wheel bridge (A)

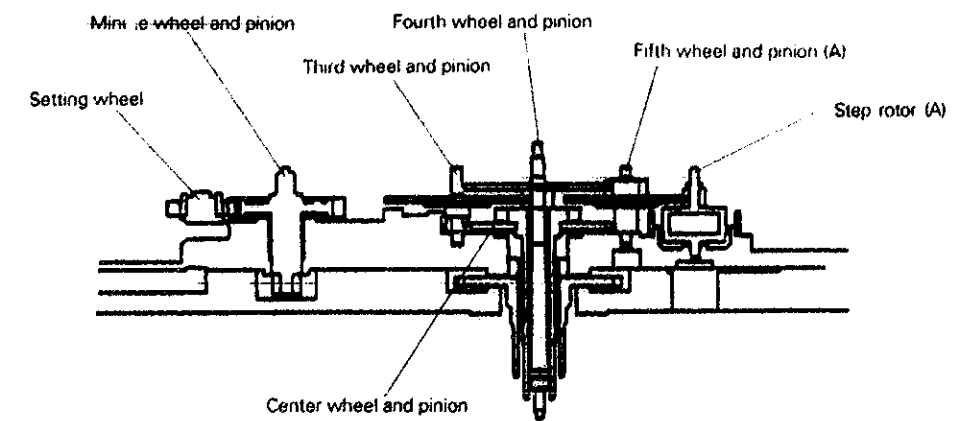

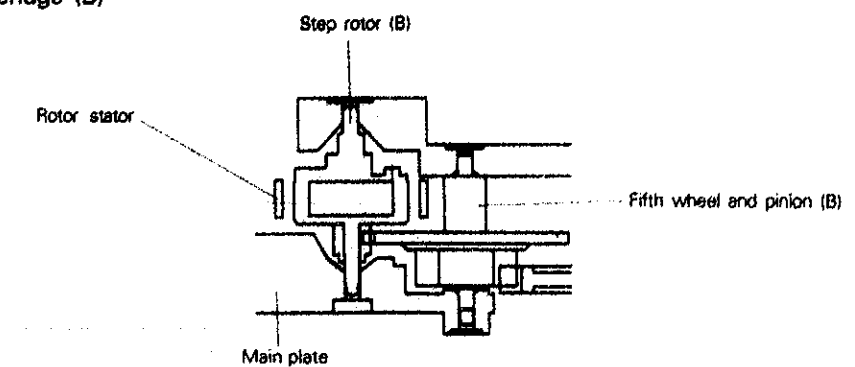

Train wheel bridge (B)



TECHNICAL GUIDE

Cal. V656A

• Distinction of wheels

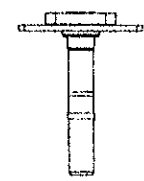
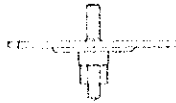
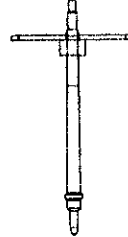
Name	Step rotor (A)	Step rotor (B)	Center wheel and pinion	Third wheel and pinion	Fourth wheel and pinion
Shape					
Parts No.	4146 890	4146 177	221 357	231 890	241 406

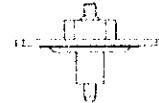
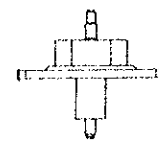
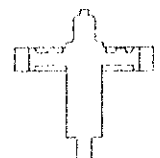
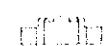
Name	Fifth wheel and pinion (A)	Fifth wheel and pinion (B)	Minute wheel and pinion	Setting wheel
Shape				
Parts No.	701 890	701 357	261 176	281 890

Remarks:

- Reassemble step rotor (B) with its pinion facing the main plate side.

TECHNICAL GUIDE

Cal. V656A

- ④6 Train wheel setting lever
- ④7 Setting lever
- ④8 Yoke

• Setting position

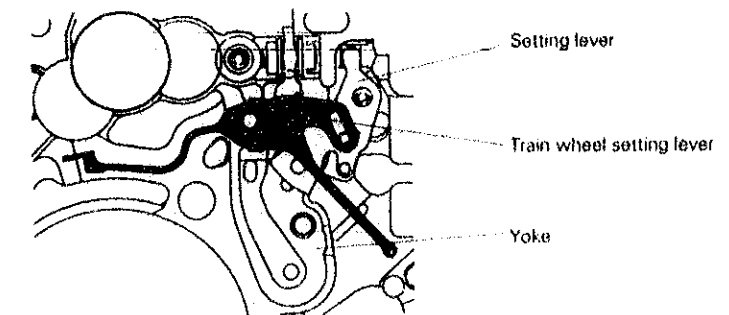

Remarks:

Check that the contact spring of the yoke is not deformed.

IV. VALUE CHECKING

• Coil block resistance

1.9K Ω ~ 2.3K Ω

• Measuring time accuracy

When measuring time accuracy, make sure that the stopwatch is stopped. Otherwise, correct accuracy cannot be obtained.

• Current consumption

For the whole movement : Less than 3.0 μ A

For the circuit block alone : Less than 1.5 μ A

Remarks:

Before measuring the current consumption, short-circuit the AC terminal of the circuit block and battery connection (+) with a conductive tweezer.