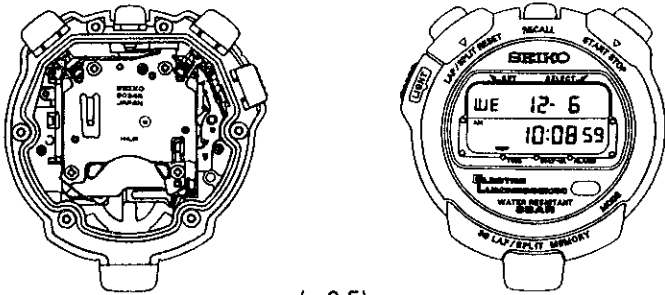

PARTS CATALOGUE / TECHNICAL GUIDE

Cal. S034A

[SPECIFICATIONS]

Item		Cal. No.	S034A
Complete			 <p>(x 0.5)</p>
Module size	Outside diameter	47.4 mm between 12 o'clock and 6 o'clock sides 40.8 mm between 3 o'clock and 9 o'clock sides	
	Casing diameter	-	
	Height	5.9 mm (9.1 mm including the battery portion)	
Display medium		Nematic Liquid Crystal, FEM (Field Effect Mode)	
Liquid crystal driving system		Multiplex driving system	
Display system		<ul style="list-style-type: none"> • Stopwatch display (Up to 10 hours in 1/100 second increments) <ul style="list-style-type: none"> • Lap time measurement display Lap time, accumulated elapsed time and lap No. • Split time measurement display Split time, accumulated elapsed time and split No. • Memory recall Up to 30 sets of lap time and split time (Each measurement is displayed in hour, minutes, seconds and 1/100 seconds) Lap/split No. (from "0" up to "99") • Alarm display (The alarm rings on a 24-hour basis) <ul style="list-style-type: none"> • Hour and minutes (The AM/PM mark is also displayed in the 12-hour indication) • Time/calendar display <ul style="list-style-type: none"> • Month, date, day, hour, minutes and seconds (The AM/PM mark is also displayed in the 12-hour indication) 	
Additional mechanism		<ul style="list-style-type: none"> • Automatic calendar (from 1995 to 2044 including February of leap years) • Confirmation sound for button operation • Resetting of the circuit • Illumination light • Battery life indicator 	
Accuracy		±0.0012 % at normal temperature range (corresponds to a loss/gain [monthly rate] of less than 30 seconds)	
Regulation system		Nil	
Measuring gate by quartz tester		Any gate can be used.	
Battery		SEIKO CR2032, Maxell CR2032, Matsushita CR2032 Battery life is approximately 3 years. Voltage: 3.0 V	

PARTS CATALOGUE

Cal. S034A

Disassembling procedure Figs. : ① → ②⑥

Reassembling procedure Figs. : ②⑥ → ①

Lubricating: Types of oil		Oil quantity
	Silicone oil 500,000 c.s.	Normal quantity
	SEIKO Watch Oil S-6	Extremely small

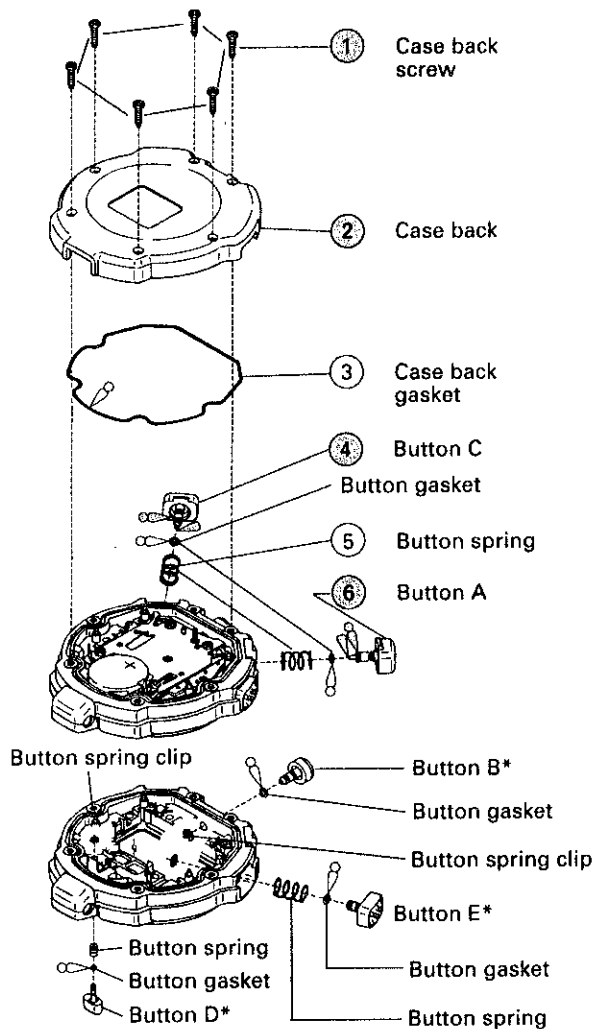

* Do not disassemble buttons B, D and E except when they need to be replaced.

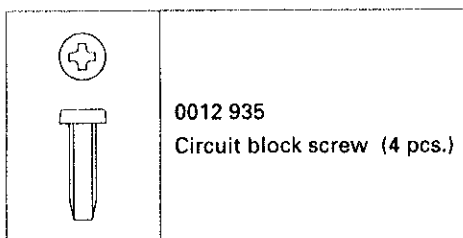

Please see the remarks on the following pages.

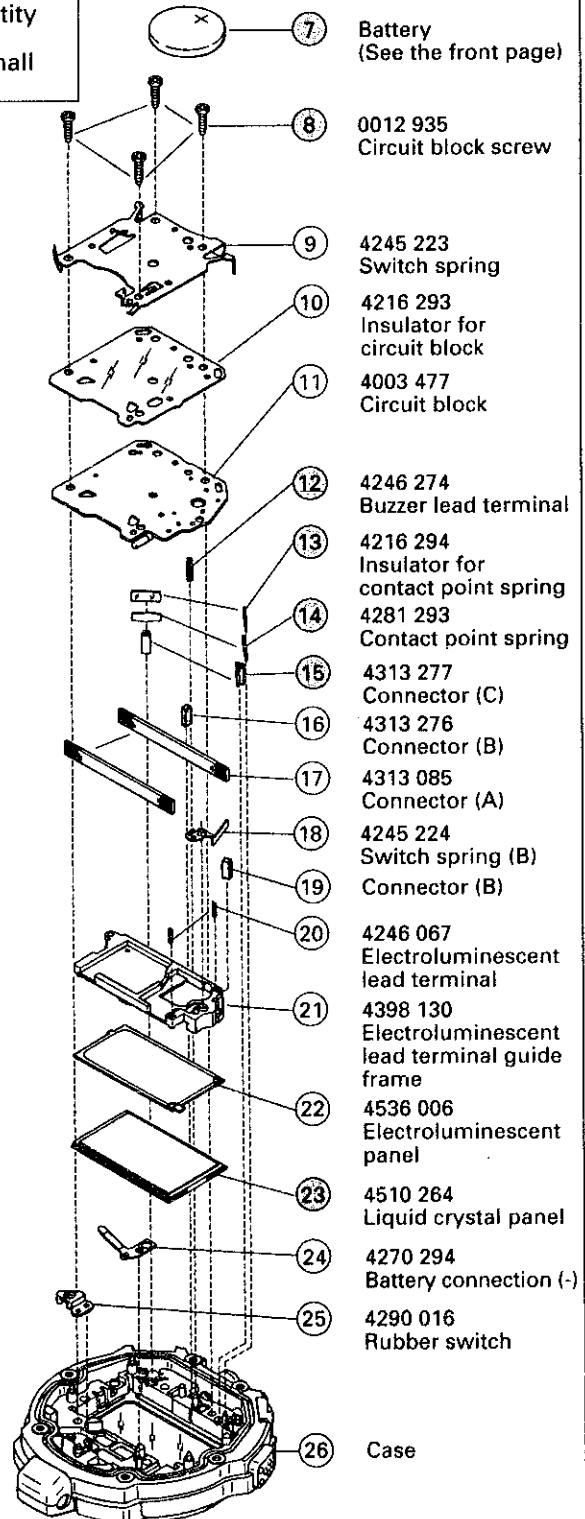

Remarks:

- Other parts

Piezoelectric element 4589 020

Adhesive tape 4447 013

The tape is used to fix the piezoelectric element to the case back. For details, refer to " ② Case back [How to replace the piezoelectric element]" on page 4.

TECHNICAL GUIDE

- The explanation here is only for the particular points of Cal. S034A.
- For the repairing, checking and measuring procedures, refer to the "TECHNICAL GUIDE, GENERAL INSTRUCTIONS".

I. STRUCTURE OF THE CIRCUIT BLOCK

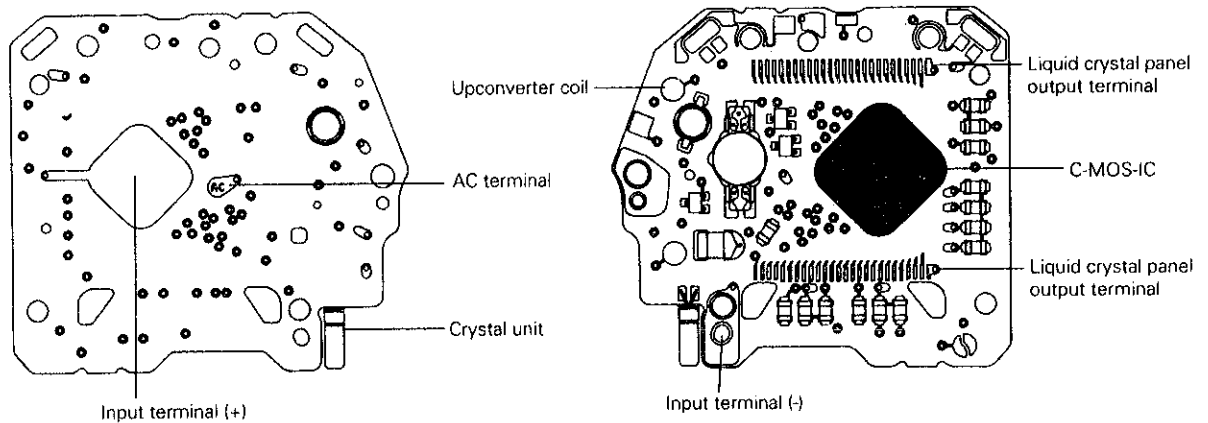

II. REMARKS ON INSTALLING THE BATTERY

- After the battery is replaced with a new one, or after the battery is re-installed following the repairing procedures, be sure to short-circuit the AC terminal of the circuit block and the switch spring (or battery (+) surface) with conductive tweezers to reset the circuit.

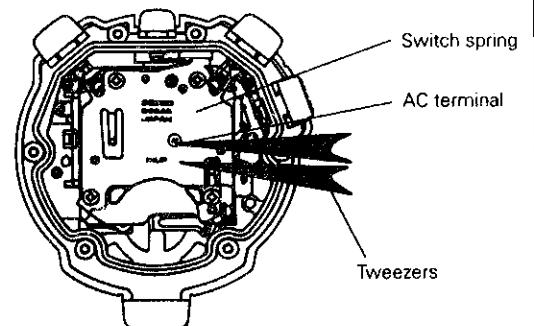

TECHNICAL GUIDE

Cal. S034A

- To reset the circuit with the case back installed, keep buttons A, B, C and D pressed at the same time for approximately 3 seconds. The display will become blank, and "SU 1-1 AM 12:00 00" will be shown as the buttons are released, indicating that the resetting of the circuit has been completed.

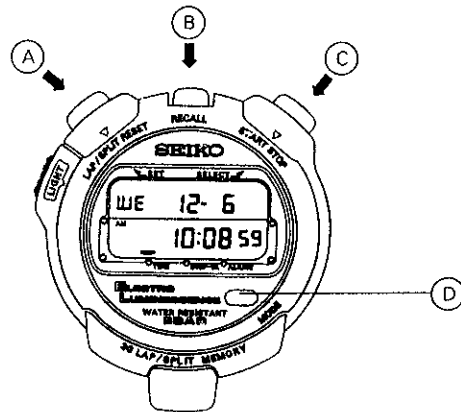

III. REMARKS ON DISASSEMBLING AND REASSEMBLING

- ① Case back screw
- ⑧ Circuit block screw

As the case back screw and the circuit block screw differ from each other in shape, refer to the illustration below for distinction.

Be careful not to tighten the screws excessively.

Case back screw

- Head diameter : small
- Length : long

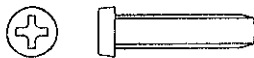

Circuit block screw

- Head diameter : large
- Length : short



- ② Case back

• How to remove the piezoelectric element with vibrating metal plate

- (1) While holding the case back, insert the tip of the screwdriver into the notch of the protruding portion of the case back.
- (2) Pry up the piezoelectric element by raising the screwdriver as shown in the illustration.

Note: Do not use the rim of the case back as the fulcrum to pry up the piezoelectric element. Otherwise, the case back will be deformed.

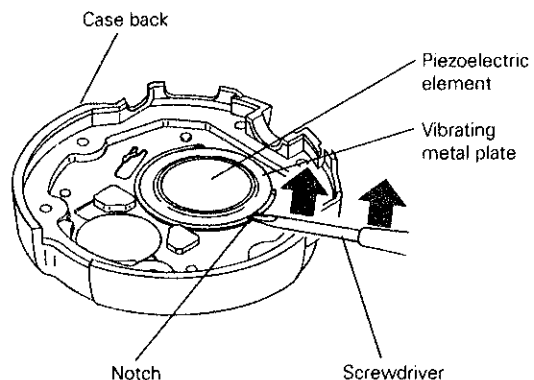

• **How to install the piezoelectric element**

- (1) Apply the adhesive tape to the protruding portion of the case back, checking that the tape does not cover the notch. Then, peel the white protective seal off the tape.
- (2) Set the piezoelectric element on the tape.
- (3) Press down the vibrating metal plate (outer circumference) of the piezoelectric element with the pointed tip of a thin wooden stick or the like to make sure that it is securely fixed to the case back.

Note: Never press down on the piezoelectric element (white portion) as this may break it.

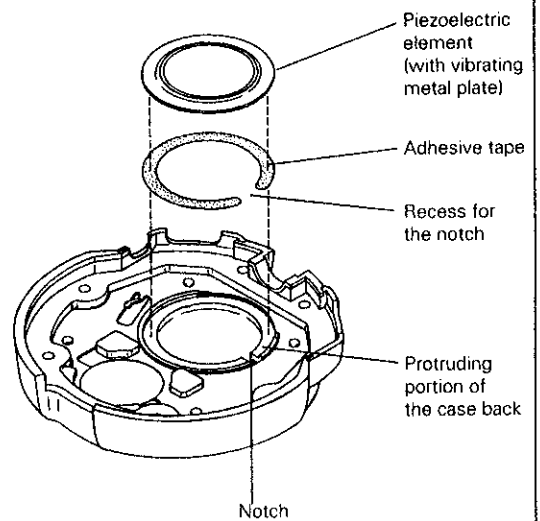

④ Button C

⑥ Button A

When removing or installing the buttons, press the indented portions of the switch springs. In doing so, hold the buttons with fingers. Otherwise, the buttons will spring out of the case.

• **Lubricating**

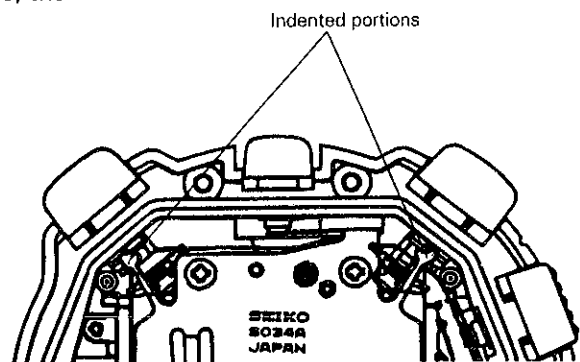
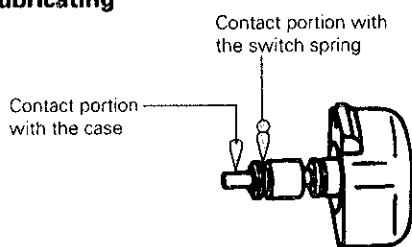

⑦ Battery

To install the battery, slip the battery sideways into the gap under the battery clamp portion of the switch spring.

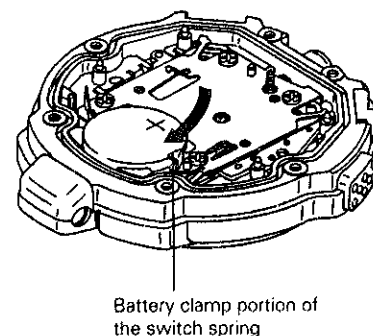

TECHNICAL GUIDE

Cal. S034A

12 Buzzer lead terminal

To install the buzzer lead terminal, set the end portion of the buzzer lead terminal into the groove of the case.

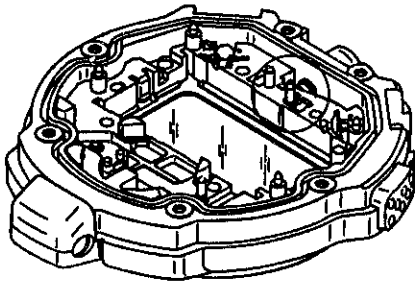

➔
Enlarged

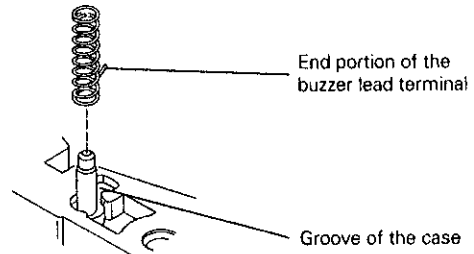

13 Insulator for contact point spring

14 Contact point spring

15 Connector (C)

Set the insulator for contact point spring, contact point spring and connector (C) into the groove of the case, checking that the contact point spring is placed between the insulator for contact point spring and connector (C).
Note that the insulator for contact point spring may be slightly tight for the groove of the case.

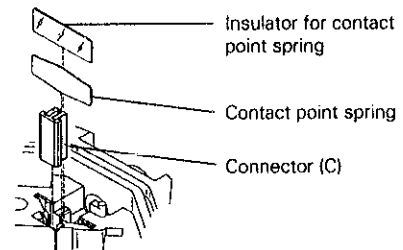

23 Liquid crystal panel

Set the liquid crystal panel with its sealing portion on the right-hand side as shown in the illustration at right.

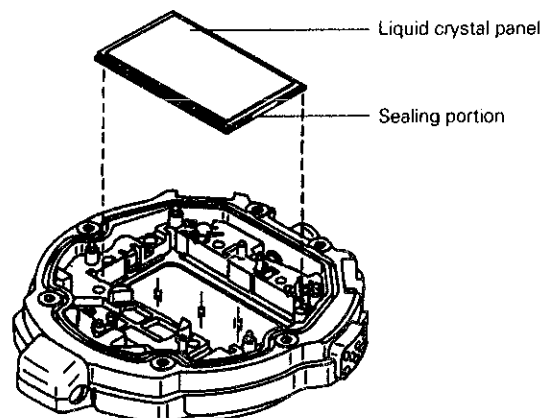

IV. VALUE CHECKING

- **Time accuracy**

To measure accuracy, light up all the segments of the display by pressing buttons A and C at the same time in the TIME/CALENDAR SETTING display.

After the measurement, press button A, B, C or D to return to the TIME/CALENDAR display.

- **Upconverter coil resistance**

120 Ω ~ 180 Ω

- **Current consumption**

For the whole of the module : less than 3.9 μ A

Note: Before measuring current consumption, be sure to reset the circuit. Otherwise, the display will become disordered, and as a result, current consumption cannot be measured properly.