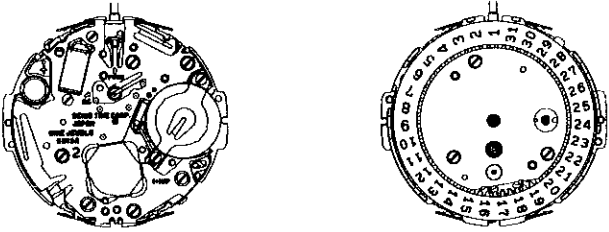

# PARTS CATALOGUE / TECHNICAL GUIDE

## Cal. 6M13A

### [SPECIFICATIONS]

Item		Cal. No.	6M13A
Movement			 <p>(x 1.0)</p>
Movement size	Outside diameter	28.5 mm between 6 o'clock and 12 o'clock sides ø27.0 mm between 3 o'clock and 9 o'clock sides	
	Casing diameter	ø26.4 mm	
	Height	3.7 mm (3.9 mm including the battery portion)	
Time indication		3 hands, 24-hour hand and mode indicator	
Driving system		Step motor (4 pcs.)	
Additional mechanism		<ul style="list-style-type: none"> <li>• One-day alarm function (24-hour indication system)</li> <li>• Daily alarm function (24-hour indication system)</li> <li>• Automatic calendar adjustment function (Year, month, date and day of the week from the year 1400 to 2499)</li> <li>• Calendar search function (The day of the week for any desired date can be displayed.)</li> <li>• Hands 0-reset adjustment function</li> <li>• Alarm test system</li> <li>• Electronic circuit reset switch</li> <li>• Battery life indicator</li> </ul>	
Loss/gain		Monthly rate at normal temperature range: less than 15 seconds	
Regulation system		Nil	
Measuring gate by quartz tester		Use 10-second gate (in "Ø MATCH" mode).	
Battery		SEIKO SR927W, Maxell SR927W, SONY SR927W, EVEREADY 399 Battery life is approximately 2 years. Voltage: 1.55V	
Jewels		9 jewels	

**SEIKO CORPORATION**

# PARTS CATALOGUE

Cal. 6M13A

Disassembling procedures Figs. : ① → ⑥①

Reassembling procedures Figs. : ⑥① → ①

Lubricating:	Types of oil	Oil quantity
○	Silicone Oil 500,000 c.s.	○ Normal quantity
●	Moebius A	
⊖	SEIKO Watch Oil S-6	

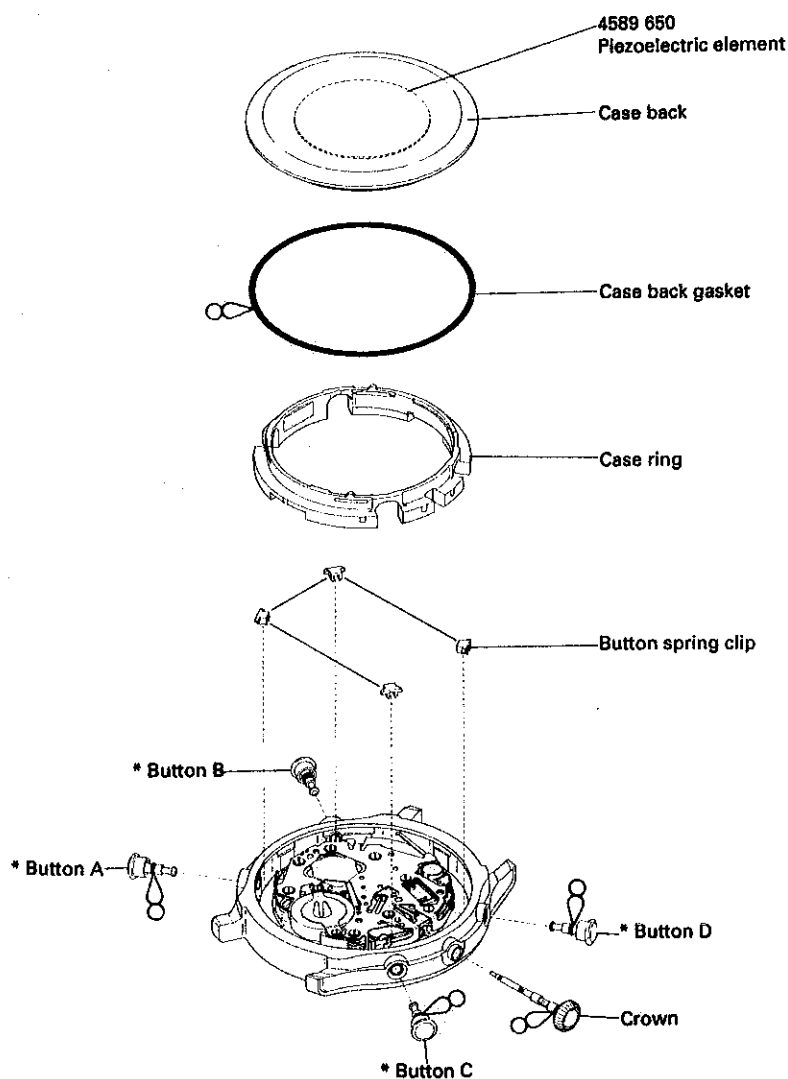

**Note:** For most of the models of Cal. 6M13A, the movement can be removed from the case by disassembling the bezel, and it is not necessary to disassemble the buttons. If the button spring clips of the type shown in the illustration are used, however, remove them first and then disassemble the buttons and crown to remove the movement.

⊖ → Please see the remarks on the following pages.

# PARTS CATALOGUE

Cal. 6M13A

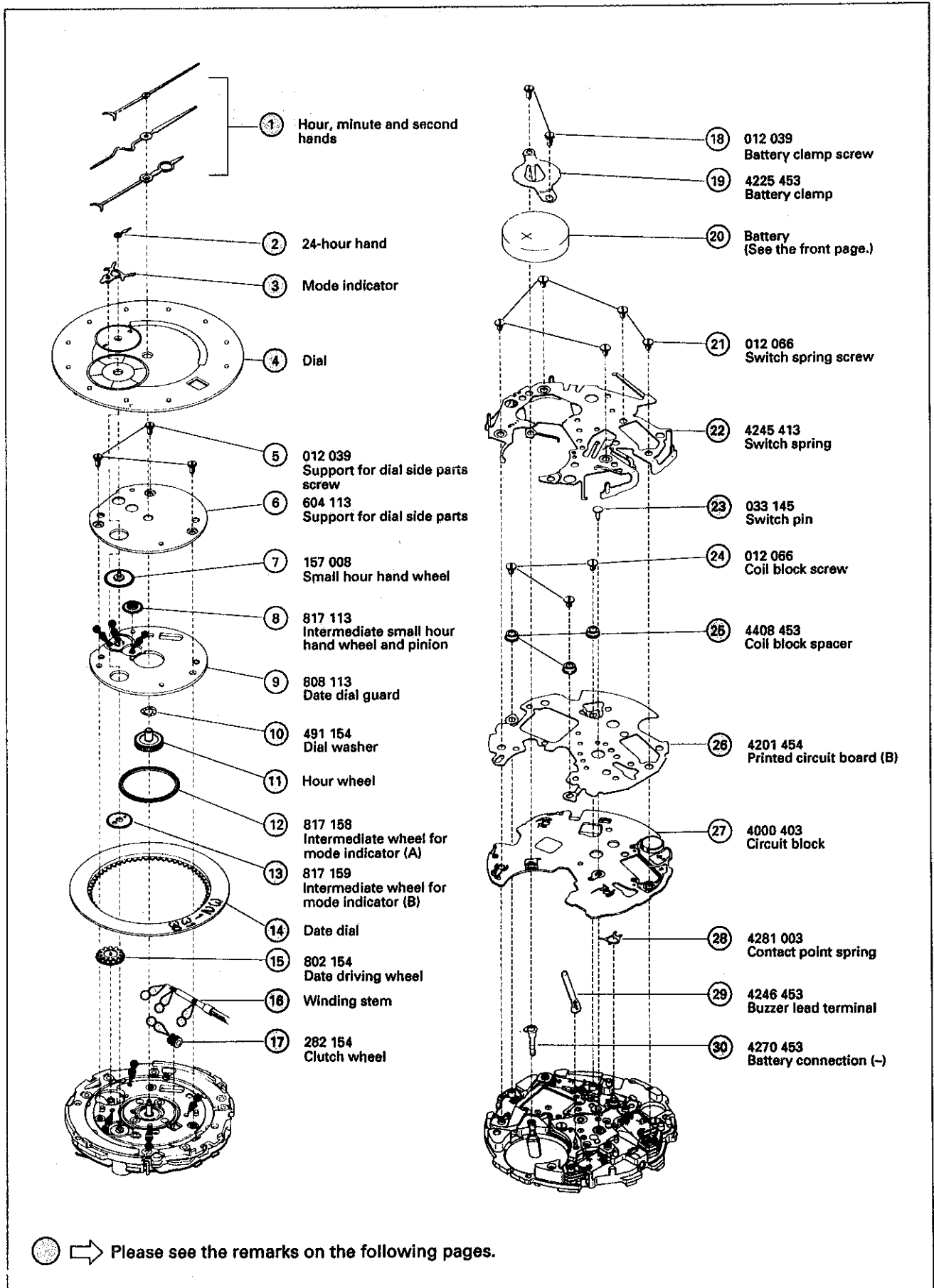

# PARTS CATALOGUE

Cal. 6M13A

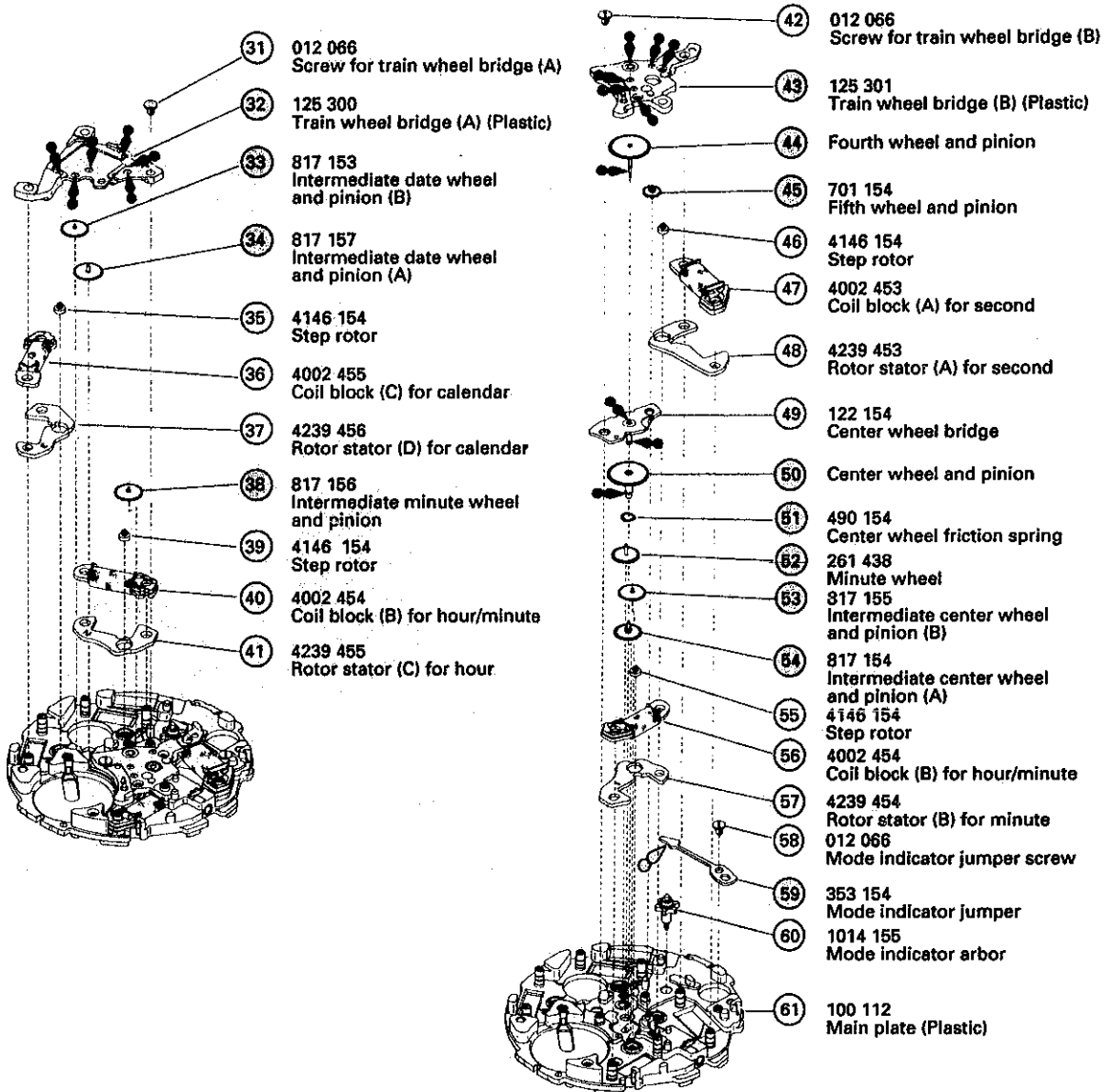

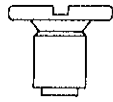
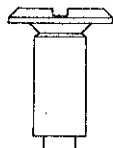
	<p>012 066</p> <ul style="list-style-type: none"> <li>• Switch spring screw (5 pcs.)</li> <li>• Coil block screw (3 pcs.)</li> <li>• Screw for train wheel bridge (A) (1 pc.)</li> <li>• Screw for train wheel bridge (B) (1 pc.)</li> <li>• Mode indicator jumper screw (1 pc.)</li> </ul>
	<p>012 039</p> <ul style="list-style-type: none"> <li>• Support for dial side parts screw (3 pcs.)</li> <li>• Battery clamp screw (2 pcs.)</li> </ul>

 Please see the remarks on the following pages.

# PARTS CATALOGUE

Cal. 6M13A

**Remarks:**



- ①① Hour wheel
- ④④ Fourth wheel and pinion
- ⑤⑤ Center wheel and pinion

• **Discrimination of the installing height of the hands**

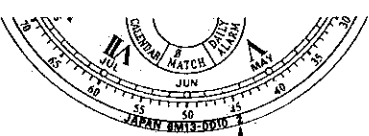
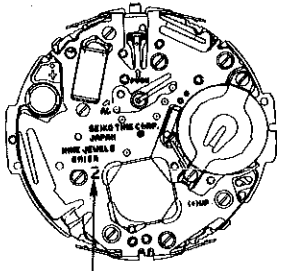
Cal. 6M13A watches have numerals printed on the dial and movement to indicate the installing heights of hands. When repairing, refer to the table below.

Discrimination	Height	Standard type	
	Numeral for discrimination	2	
Printed on		Dial	Movement
Printed position		 <p>The numeral is printed at the right end.</p>	 <p>The numeral is printed below the calibre number.</p>

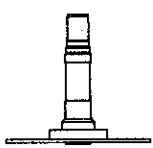
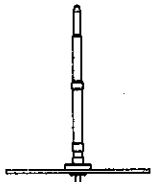
\* The installing heights of the hands can be known from the shape of the following parts. Refer to the table below.

Numeral for discrimination	Center wheel and pinion	Fourth wheel and pinion	Hour wheel
2	 <p>221 113</p>	 <p>241 223</p>	 <p>271 413</p>

# PARTS CATALOGUE

Cal. 6M13A

## 14 Date dial

Part code	Position of crown and calendar	Color of figure	Color of background
801 466	3 o'clock	Black	White

The type of date dial is determined based on the design of cases.  
Check the case number and refer to "SEIKO CASING PARTS CATALOGUE" to choose a corresponding date dial.

## 16 Winding stem 351 168

The type of winding stem is determined based on the design of cases.  
Check the case number and refer to "SEIKO CASING PARTS CATALOGUE" to choose a corresponding winding stem.

# TECHNICAL GUIDE

Cal. 6M13A

- The explanation here is only for the particular points of Cal. 6M13A.
- For the repairing, checking and measuring procedures, refer to the "TECHNICAL GUIDE, GENERAL INSTRUCTIONS".

## I. STRUCTURE OF THE CIRCUIT BLOCK

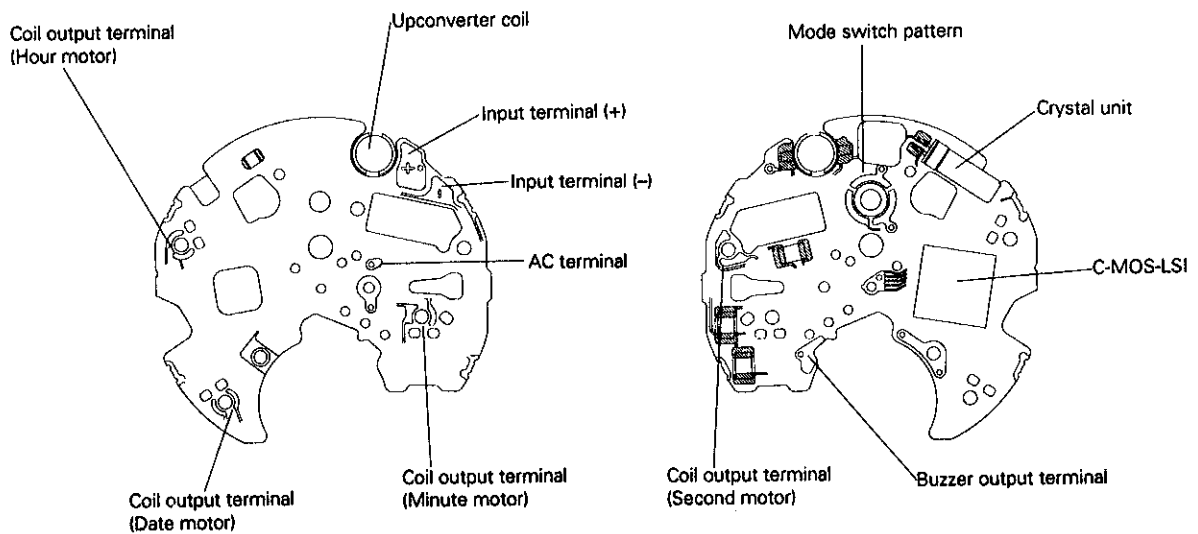

## II. REMARKS ON INSTALLING THE BATTERY

- After the battery is replaced with a new one, or after the battery is re-installed following the repairing procedures, be sure to short-circuit the AC terminal of the circuit block and the battery connection (+) with conductive tweezers to reset the circuit as shown in the illustration below. (When checking the current consumption, short-circuit with the power supplied from external source.)

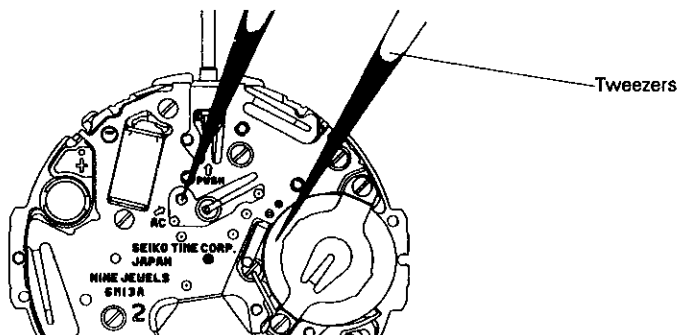

- To reset the circuit of the complete watch, follow the procedure below.

- (1) Turn the crown to set the mode indicator to "Ø MATCH".
- (2) Pull out the crown.
- (3) Keep buttons "A", "B", "C" and "D" pressed at the same time for approximately 3 seconds. When the buttons are released, a beep sounds and the hands turn a full circle once or twice.

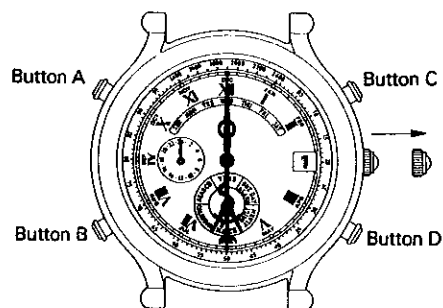

- (4) Reset the tips of the hands to the "12" o'clock position.
  - With each press of button "C", the second hand advances one second.
  - With each press of button "A", the minute hand advances one minute. When setting the minute hand, check that the tail of the minute hand indicates 50 minutes.
  - With each press of button "B", the hour hand advances one hour. When setting the hour hand, check that the 24-hour hand is set to "24" position.
- (5) Press button "D" to put the date to "1". With each press of the button, the date moves slightly.
- (6) Push the crown back in to the normal position.
  - \* The hands move quickly if the respective buttons are kept pressed for 2 seconds.
- (7) Turn the crown to set the mode indicator to "TIME" to set the desired time and turn it to "CALENDAR" to set the desired year, month and date.

### III. REMARKS ON DISASSEMBLING AND REASSEMBLING

Use the universal movement holder for disassembling and reassembling.

- ① Hands    ② 24-hour hand

Since a plastic main plate is used, place the movement on a flat metal plate or the like, and then install the hour, minute and second hands at the 12 o'clock position and the 24-hour hand at "24" position, respectively.

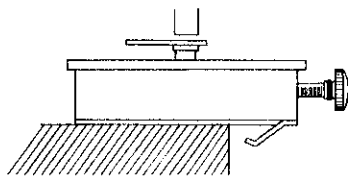

[Tip of the hands : For time indication]

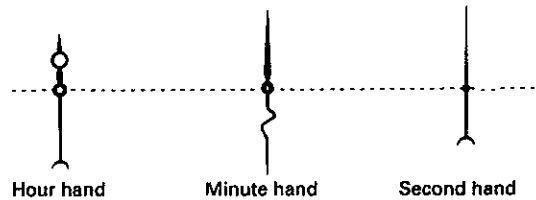

[Tail of the hands : For calendar indication]

- ③ Mode indicator

• How to remove

Set a hand-removing jig at the center of the mode indicator to remove it. In doing so, check that the hand-removing jig is set right at the center of the mode indicator. Otherwise, the mode indicator may be deformed.

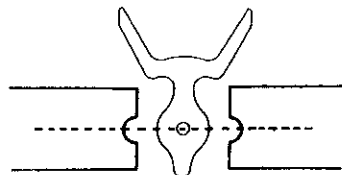

[Correct]

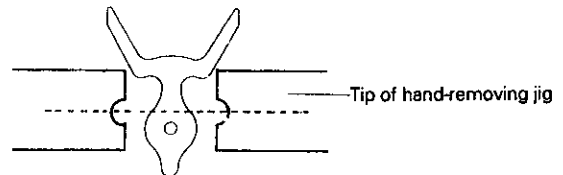

[Incorrect]

• How to install

Place the movement on a flat metal plate or the like, and then set the mode indicator and the mode indicator arbor following the procedure below.

- (1) Turn the crown to set the notched portion of the mode indicator arbor at the 6 o'clock position.

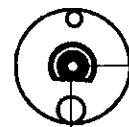
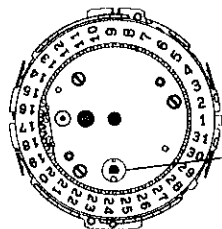

Mode indicator arbor

Set the notched portion at the 6 o'clock position.



# TECHNICAL GUIDE

Cal. 6M13A

(2) Install the mode indicator so that it points to "TIME".

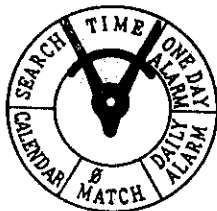

(3) After installing the mode indicator, give it three full turns by turning the crown to check if it stops exactly at the respective mode positions.

If the mode indicator arbor is loose in the contact with the mode indicator's pipe, the mode indicator will stop out of the proper positions. In that case, slightly flatten the mode indicator's pipe at the part indicated in the illustration, and then install the mode indicator to the mode indicator arbor again.

Mode indicator's pipe (Flatten here.)

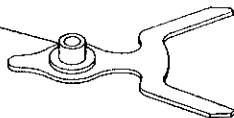

④ Dial

Pry up the dial at the two recessed parts indicated in the illustration using a screwdriver.

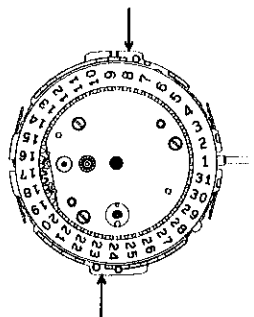

⑩ Dial washer

• How to distinguish the two parts

[Dial washer]

• With the larger diameter



[Center wheel friction spring]

• With the smaller diameter



⑤① Center wheel friction spring

• Setting position

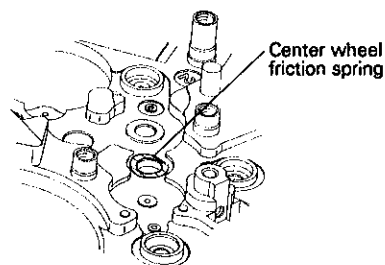

## 13 Intermediate wheel for mode indicator (B)

### • How to install

Set the intermediate wheel for mode indicator (B) to the mode indicator arbor so that it fits in with the notched part of the mode indicator arbor.

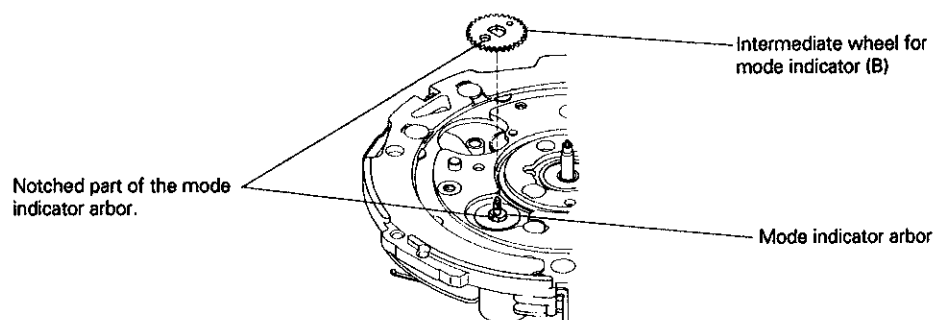

## 14 Date dial

### • How to install

Since a plastic date dial is used, make sure that the teeth of the date dial and the date driving wheel securely mesh with each other.

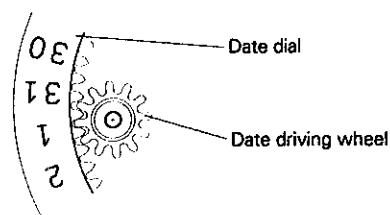

## 16 Winding stem

### • How to remove

Remove the winding stem while pushing the indented portion of the switch spring (marked with "← PUSH").

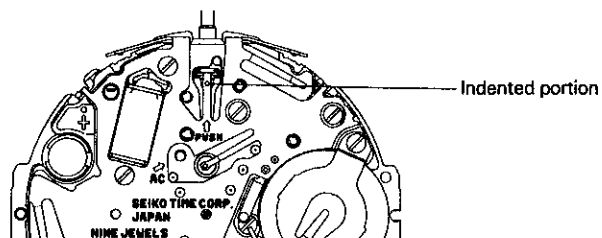

## 17 Clutch wheel

### • How to install

Be sure to install the clutch wheel in the direction as shown in the illustration.

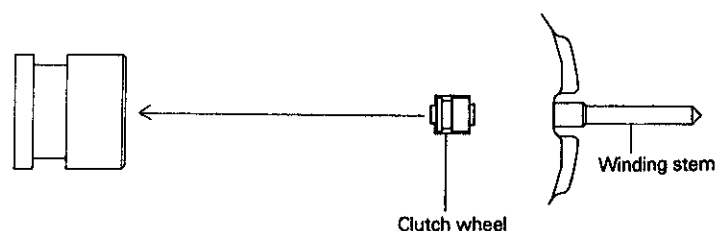

# TECHNICAL GUIDE

Cal. 6M13A

## 22 Switch spring

### • How to install

Set the three hooking portions of the switch spring to the main plate.

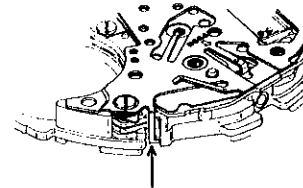
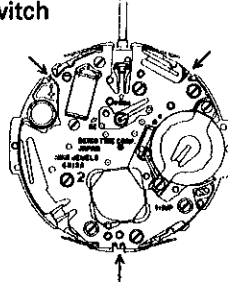

Take care not to deform the switch spring when disassembling or reassembling it.

## 23 Switch pin

Check that proper clearance is provided between the switch pin and circuit block.

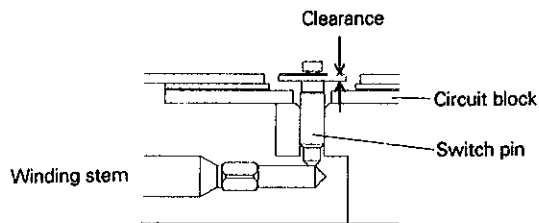

Crown at the normal position : Clearance provided.  
Crown at the extended position : No clearance provided.

## 25 Coil block spacer

### • How to install

Take care not to install up side down.

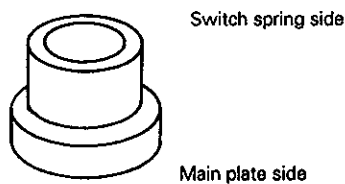

## 26 Printed circuit board (B)

### • How to remove

Catch the protrusion of the printed circuit board and pull it up to remove.

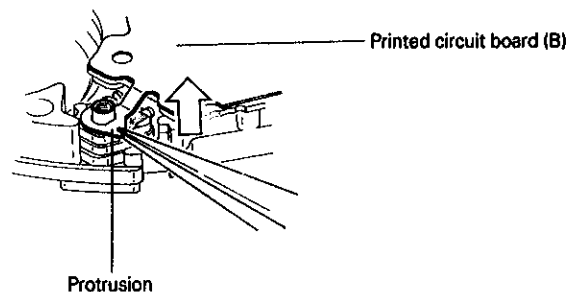

## 28 Contact point spring

### • Setting position

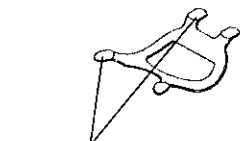

Check if the contacting portion with the circuit block is deformed.

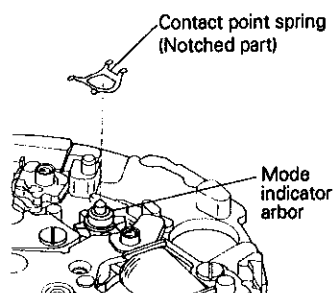

Set the contact point spring to the mode indicator arbor so that it fits in with the notched part of the mode indicator arbor.

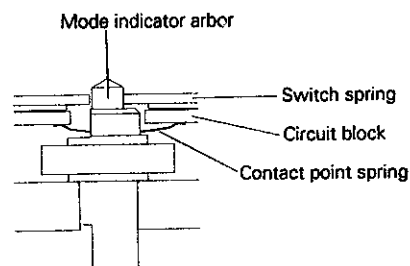

## 30 Battery connection (-)

### • How to install

Set the battery connection (-) along the guide groove of the main plate.

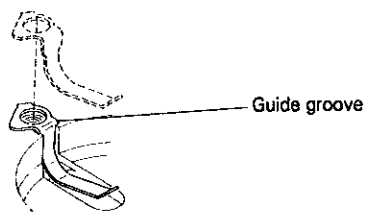

**32 Train wheel bridge (A) (Plastic)**

• **Setting position**

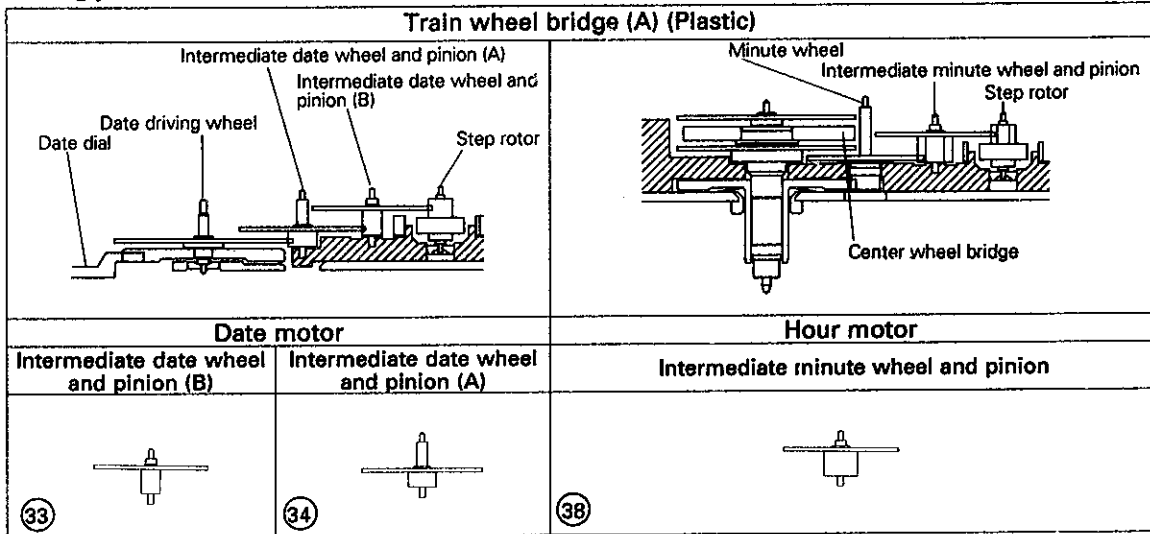

**43 Train wheel bridge (B) (Plastic)**

• **Setting position**

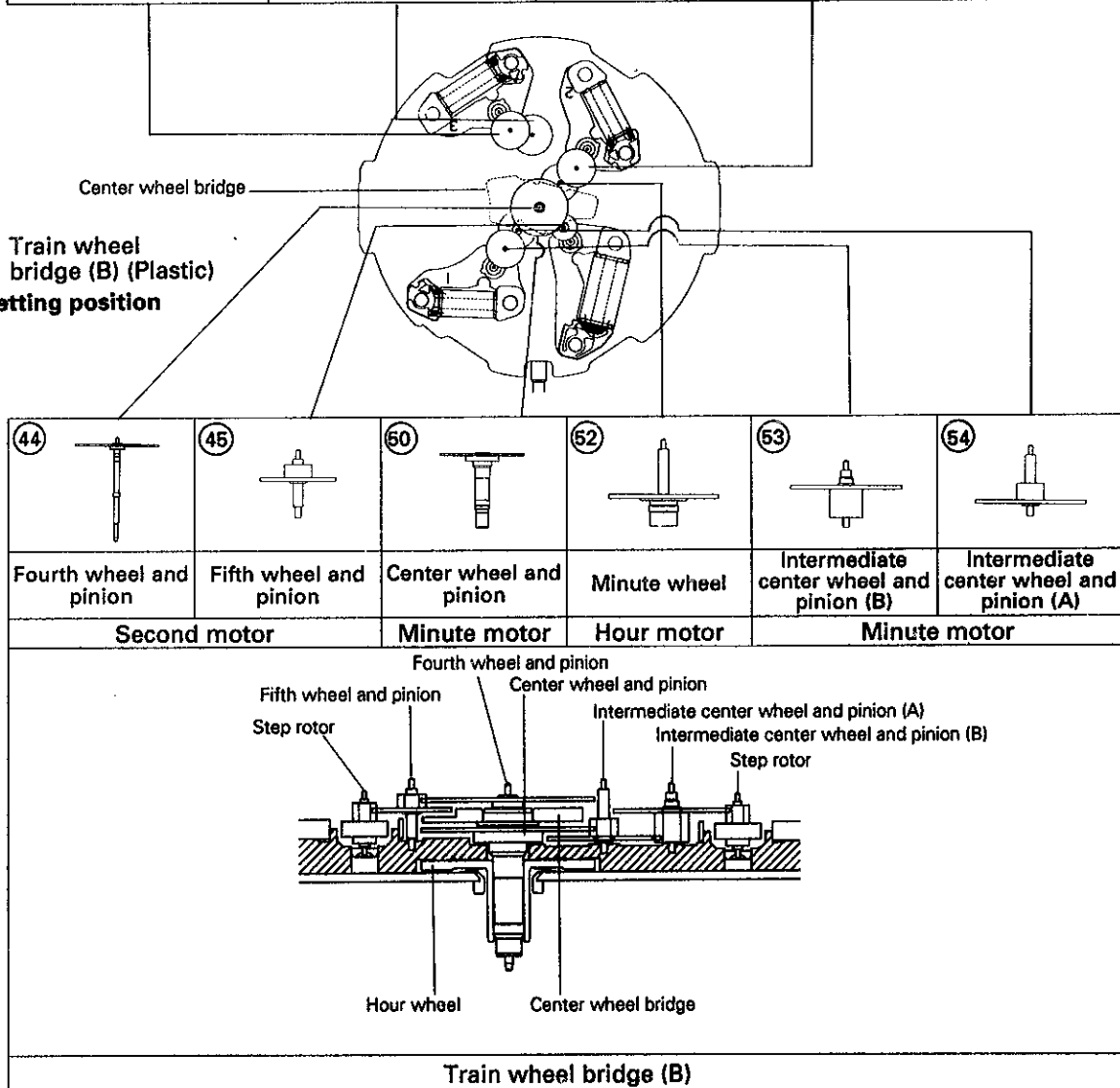





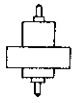

\* For the distinction of parts of respective motors, see the next page.

# TECHNICAL GUIDE

Cal. 6M13A

• **Distinction of motors**

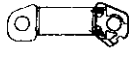
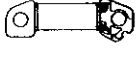
Distinction Part name	Second motor	Minute motor	Hour motor	Date motor
Step rotor				
Rotor stator	 No mark	 Marked with "1"	 Marked with "2"	 Marked with "3"
Coil block	 Mold agent: Blue Larger diameter	 Mold agent: Green Standard diameter		 Mold agent: Red Smaller diameter

⑤ Mode indicator jumper

Take care not to deform the mode indicator jumper when disassembling or reassembling it, as extremely high pressure is applied to it.

• **How to remove**

Release the tip of the mode indicator jumper from the mode indicator arbor, and then lift up "A" portion in the illustration.

• **How to install**

Reverse the procedures for disassembling.

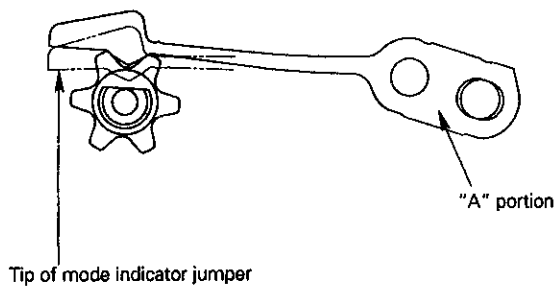

## IV. VALUE CHECKING

### • Coil block resistance

Coil block for second motor	:	1.5K $\Omega$ ~ 1.9K $\Omega$
Coil block for minute and hour motor	:	1.2K $\Omega$ ~ 1.6K $\Omega$
Coil block for date motor	:	0.8K $\Omega$ ~ 1.2K $\Omega$

### • Upconverter coil resistance

120 $\Omega$  ~ 180 $\Omega$

### • Measuring time accuracy

- [1] Turn the crown to set the mode indicator to "Ø MATCH".
- [2] Set the gate of the quartz tester to "10" and then put the watch on the microphone.

#### **Note:**

To measure the time accuracy, be sure to set the watch in the "Ø MATCH" mode and check that the stopwatch has been reset. A small amount of output signal is constantly generated for the measurement use. If the measurement is made in the "TIME" mode with the hands moving, no stable measurement can be obtained.

### • Current consumption

For the whole of the movement	:	less than 3.0 $\mu$ A
For the circuit block alone	:	less than 0.8 $\mu$ A

- [1] Tighten the two battery clamp screw, and install the dial, hands and mode indicator.
- [2] Turn the crown to set the mode indicator to "TIME", and supply the power from the external source.
- [3] Short-circuit the AC terminal of the circuit block and the switch spring to reset the circuit. Then measure the current consumption.

#### **Note:**

The motors move the hands and date calendar at the following intervals.

- Second motor: 1-second intervals
- Minute motor : 10-seconds intervals
- Hour motor : 2-minutes intervals
- Date motor : 24-hours intervals

Calculate the current consumption following the formula below.

$$\text{Current consumption of second motor} + \frac{\text{Current consumption of minute motor} - \text{Current consumption of second motor}}{10^*} = \text{Current consumption of movement}$$

(Ex.)

$$1.5 (\mu\text{A}) - \frac{2.5 (\mu\text{A}) - 1.5 (\mu\text{A})}{10} = 1.6 (\mu\text{A})$$

\* The value of the numerator represents the current consumption of the minute motor, which moves at 10-second intervals. To obtain the current consumption to a second, it should be divided by "10".

**Note:**

To obtain the current consumption of the movement, it is necessary to add up the measured values of all the motors by converting them to the values to a second. However, the hour and minute motors' current consumption to a second is so small that it will not affect the aggregate of the current consumption. Therefore, it is safely assumed that the above formula represents the current consumption of the movement.