

SEIKO

QUARTZ

Cal. 2C20A, 2C21A

**PARTS
CATALOGUE**

Cal. 2C20A, 2C21A



125 211



125 212



139 213



231 214



231 215



☆241 212



261 121



☆270 212



☆270 214



☆271 123



☆271 216



281 211



282 122



☆351 225



☆351 226



383 213



384 213



388 211



391 211



391 212



491 121



491 122



493 120



493 130



701 211



4000 211



4000 212



4002 211



4002 212



4146 211



4146 212



4219 211



4219 212



4239 211



4239 212



4270 211



4270 212



4408 211



4408 213



4408 214



4457 211



4457 213



☆SEIKO TR521SW



012 490



012 796



012 799



012 820



017 596



017 665



017 666



017 669



017 671



017 672

Cal. 2C20A, 2C21A

Characteristics

Casing diameter : 15.1 mm
 Maximum height : 2.2 mm (Cal. 2C20A), 2.4 mm (Cal. 2C21A) without battery
 Jewels : 2 j
 Frequency of quartz crystal oscillator : 32,768 Hz (Hz=Hertz Cycles per second)
 Driving system : Step motor (2 poles)
 Regulation system : Trimmer condenser
 Train wheel setting
 Battery life indicator (Cal. 2C21A)

PART NO.	PART NAME	PART NO.	PART NAME
125 211	Train wheel bridge (Cal. 2C21A)	4146 211	Step rotor (Cal. 2C21A)
125 212	Train wheel bridge (Cal. 2C20A)	4146 212	Step rotor (Cal. 2C20A)
139 213	Lower bridge for third wheel	4219 211	Battery connection insulator (Cal. 2C21A)
231 214	Third wheel & pinion (Cal. 2C21A)	4219 212	Battery connection insulator (Cal. 2C20A)
231 215	Third wheel & pinion (Cal. 2C20A)	4239 211	Rotor stator (Cal. 2C21A)
☆241 211	Fourth wheel & pinion (Cal. 2C21A)	4239 212	Rotor stator (Cal. 2C20A)
☆241 212	Fourth wheel & pinion (Cal. 2C21A)	4225 211	Battery clamp
261 121	Minute wheel	4239 211	Rotor stator (Cal. 2C21A)
☆270 211	Center minute wheel (Cal. 2C21A)	4239 212	Rotor stator (Cal. 2C20A)
☆270 212	Center minute wheel (Cal. 2C21A)	4270 211	Battery connection (-) (Cal. 2C21A)
☆270 213	Center minute wheel (Cal. 2C20A)	4270 212	Battery connection (-) (Cal. 2C20A)
☆270 214	Center minute wheel (Cal. 2C20A)	4408 211	Circuit block spacer (Cal. 2C21A)
☆271 121	Hour wheel (Cal. 2C21A)	4408 213	Setting lever spring spacer
☆271 123	Hour wheel (Cal. 2C21A)	4408 214	Circuit block spacer (Cal. 2C20A)
☆271 215	Hour wheel (Cal. 2C20A)	4457 211	Circuit block cover (Cal. 2C21A)
☆271 7 6	Hour wheel (Cal. 2C20A)	4457 213	Circuit block cover (Cal. 2C20A)
281 211	Setting wheel	011 334	Upper hole jewel for step rotor
282 122	Clutch wheel	011 334	Lower hole jewel for step rotor
☆351 225	Winding stem	012 466	Battery clamp screw
☆351 226	Winding stem	012 490	Train wheel bridge screw
☆351 227	Winding stem	012 490	Coil block screw
383 213	Setting lever	012 796	Screw for lower bridge for third wheel
384 213	Yoke	012 799	Circuit block screw
388 211	Setting lever spring	012 820	Setting lever spring screw
391 211	Train wheel setting lever (Cal. 2C21A)	017 596	Minute wheel pin
391 212	Train wheel setting lever (Cal. 2C20A)	017 665	Tube for train wheel bridge (A)
491 121	Dial washer (Cal. 2C21A)	017 666	Tube for train wheel bridge (B)
491 122	Dial washer (Cal. 2C20A)	017 669	Tube for coil block
493 120	Hour wheel ring (Thickness 0.03 mm) (Cal. 2C21A)	017 671	Tube for circuit block (A)
493 121	Hour wheel ring (Thickness 0.05 mm) (Cal. 2C21A)	017 672	Tube for circuit block (B)
493 122	Hour wheel ring (Thickness 0.07 mm) (Cal. 2C21A)	☆SEIKO TR521SW	Silver (II) oxide battery
493 130	Hour wheel ring (Thickness 0.03 mm) (Cal. 2C20A)		
493 131	Hour wheel ring (Thickness 0.05 mm) (Cal. 2C20A)		
493 132	Hour wheel ring (Thickness 0.07 mm) (Cal. 2C20A)		
701 211	Fifth wheel & pinion (Cal. 2C21A)		
4000 211	Circuit block (Cal. 2C21A)		
4000 212	Circuit block (Cal. 2C20A)		
4002 211	Coil block (Cal. 2C21A)		
4002 212	Coil block (Cal. 2C20A)		

☆⇨ Please see remarks on the reverse page.

Part numbers in light letters are not shown in photos.

Cal. 2C20A, 2C21A







Remarks :

Fourth wheel & pinion, Center minute wheel, Hour wheel.



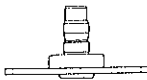

There are two different types as specified below.

Combination :

Cal. 2C20A

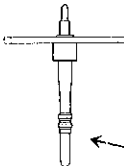
Type	Fourth wheel & pinion	Center minute wheel	Hour wheel
a		 ☆270 213	 ☆271 215
b		 ☆270 214	 ☆271 216

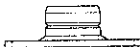
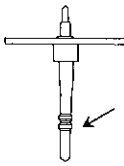
Cal. 2C21A

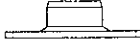
Type	Fourth wheel & pinion	Center minute wheel	Hour wheel
a	 ☆241 211	 ☆270 211	 ☆271 121
b	 ☆241 212	 ☆270 212	 ☆271 123

Winding stem

- ☆351 225 } Refer to the photograph on the front page.
 ☆351 226 }If the combination of the winding stem and case is unknown, check the case number
 ☆351 227 } and refer to "SEIKO Quartz Casing Parts Catalogue" to choose a corresponding winding stem.

Battery

- ☆SEIKO TR521 SW.....The substitutive battery might be added to the applied battery in the future.
 In that case, please refer to separate "BATTERY LIST FOR SEIKO QUARTZ WATCHES".

TECHNICAL GUIDE

SEIKO
QUARTZ

CAL. 2C20A
CAL. 2C21A

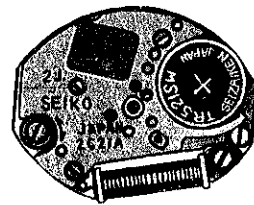
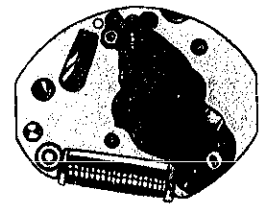

CONTENTS

I. SPECIFICATIONS	1
II. STRUCTURE OF THE CIRCUIT BLOCK	1
III. DISASSEMBLING, REASSEMBLING, AND LUBRICATING	2
1. Hour, minute, and second hands ~ Center minute wheel	2
2. Circuit block screw ~ Coil block	3
3. Train wheel bridge screw ~ Clutch wheel	4
IV. CHECKING AND ADJUSTMENT	5
• Check output signal	5
• Check battery voltage	5
• Check reset and train wheel setting condition	5
• Check battery conductivity	6
• Check conductivity of circuit block	6
• Check coil block	6
• Check gear train mechanism	7
• Check setting mechanism	7
• Check current consumption	7
• Check accuracy	8
• Check battery life indicator	8
• Check water resistance	8
• Check appearance and functioning	8

I. SPECIFICATIONS

Cal. No.		2C20A	2C21A
Item			
Time indication		2 hands	3 hands
Additional mechanism		Train wheel setting device	
		Electronic circuit reset switch	
		—	Battery life indicator
Loss/gain		Monthly rate at normal temperature range: less than 15 seconds	
Movement size	Outside diameter	$\phi 15.5$ mm (15.5 mm between 6 o'clock and 12 o'clock sides) (13.0 mm between 3 o'clock and 9 o'clock sides)	
	Casing diameter	$\phi 15.1$ mm	
	Height	2.2 mm without battery	2.4 mm without battery
Regulation system		Trimmer condenser	
Measuring gate by quartz tester		Use 10-second gate	Any gate is available.
Battery		SEIKO (SEIZAIKEN) TR521SW Voltage 1.55 V	
Battery life		Approximately 3 years	Approximately 2 years
Jewels		2 jewels	



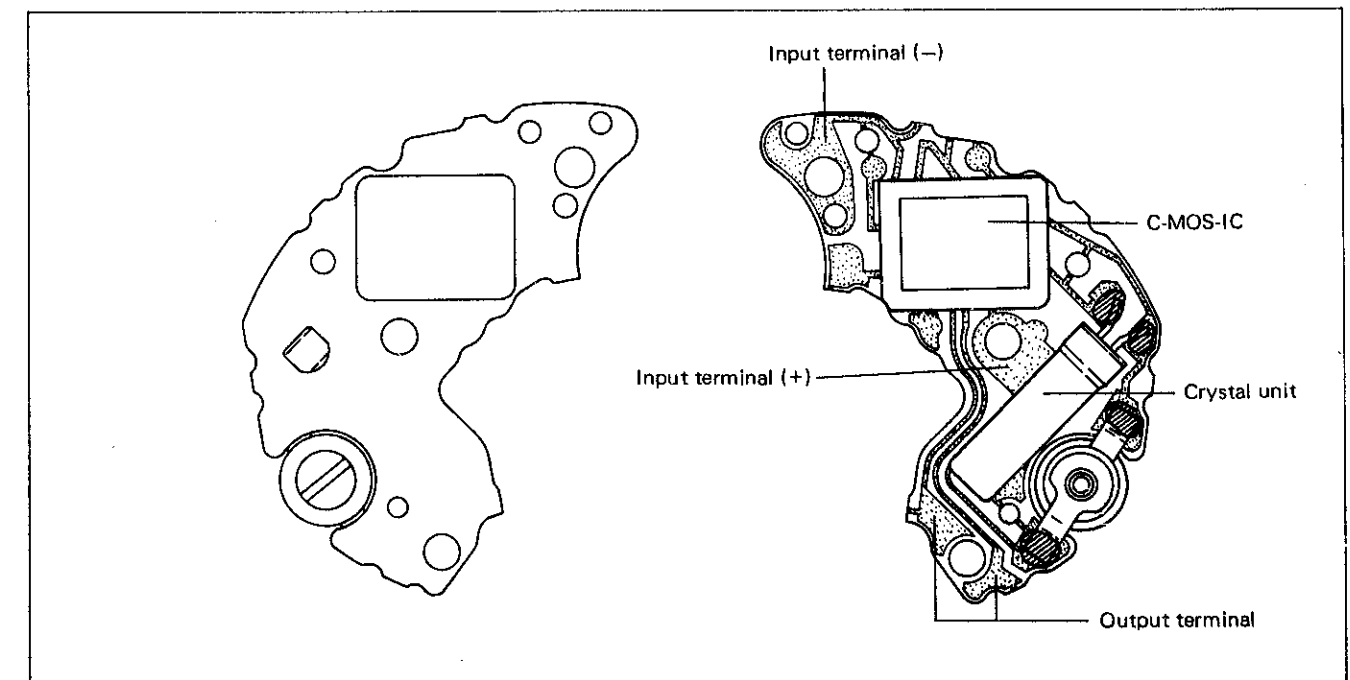

II. STRUCTURE OF THE CIRCUIT BLOCK



III. DISASSEMBLING, REASSEMBLING AND LUBRICATING

Ex.: Cal. 2C21A

List of the screws used

Shape	Part No.	Name	Shape	Part No.	Name
	012 490	Train wheel bridge screw Coil block screw		012 799	Circuit block screw
	012 796	Screw for lower bridge for third wheel		012 820	Setting lever spring screw

Disassembling procedures Figs.: ① → ③③

Reassembling procedures Figs.: ③③ → ①

Lubricating:

Types of oil

○ Moebius A

● SEIKO Watch Oil S-6

Oil quantity

○ Normal

○ Extremely small

● Use the movement holder S-664 for disassembling and reassembling.

1. Hour, minute, and second hands ~ Center minute wheel.

② Dial

● How to remove

Insert a screwdriver gently into the arrow-marked clearance between the dial and the main plate, and remove the dial from the main plate by prizing it up from the both ends.

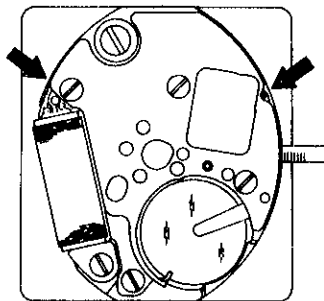

● How to set

Put the dial legs into the holes of the main plate and set so that there is no clearance between the dial and the main plate.

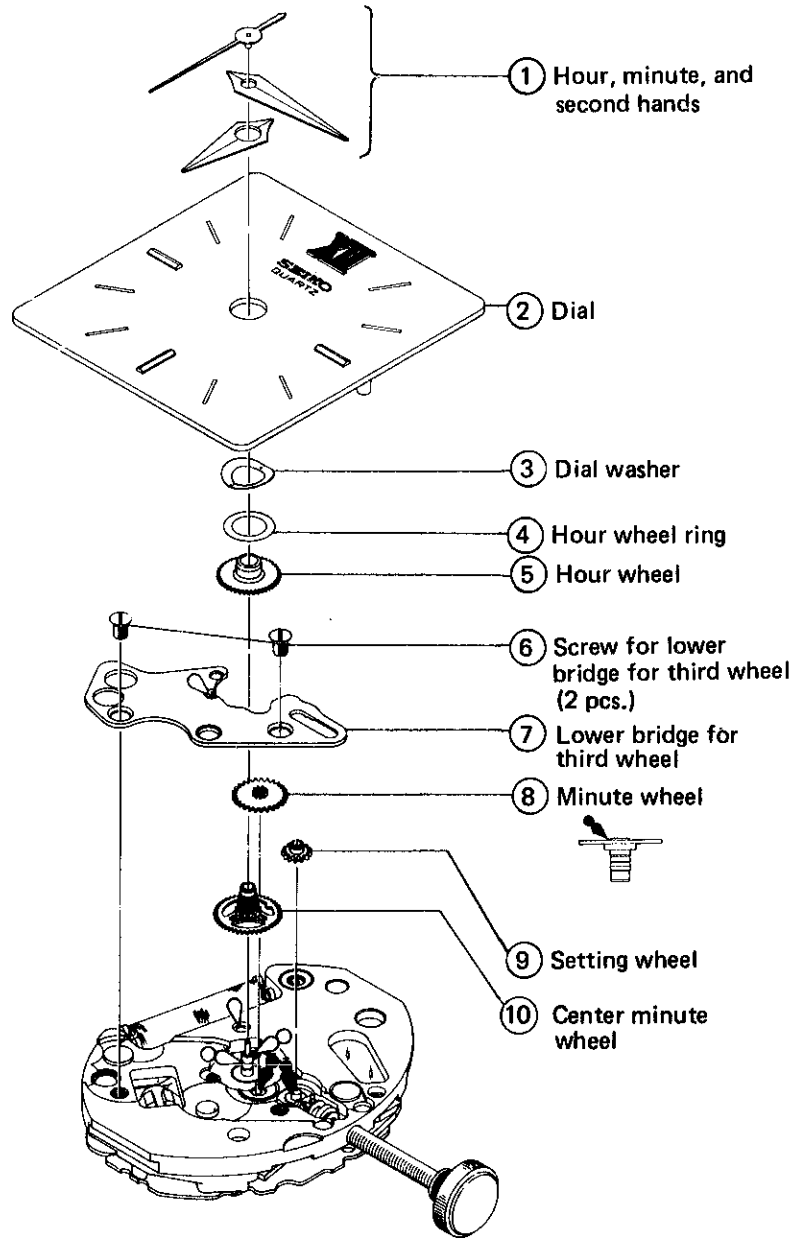

2. Circuit block screw ~ Coil block

⑭ Battery connection (-) (in case of Cal. 2C20A)

Set the tip of the battery connection (-) between the sheets of a battery connection insulator which is folded as below.

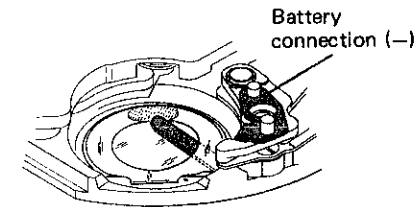

Battery connection insulator

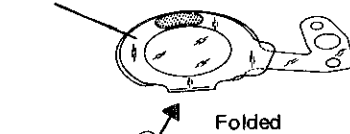

Folded

⑮ Circuit block spacer

Before installing the circuit block spacer, push the crown in to the normal position. If it is installed with the crown at the first click position, the reset portion of the yoke may be deformed or the reset pin may come up. Make sure that the reset pin is set in a right position.

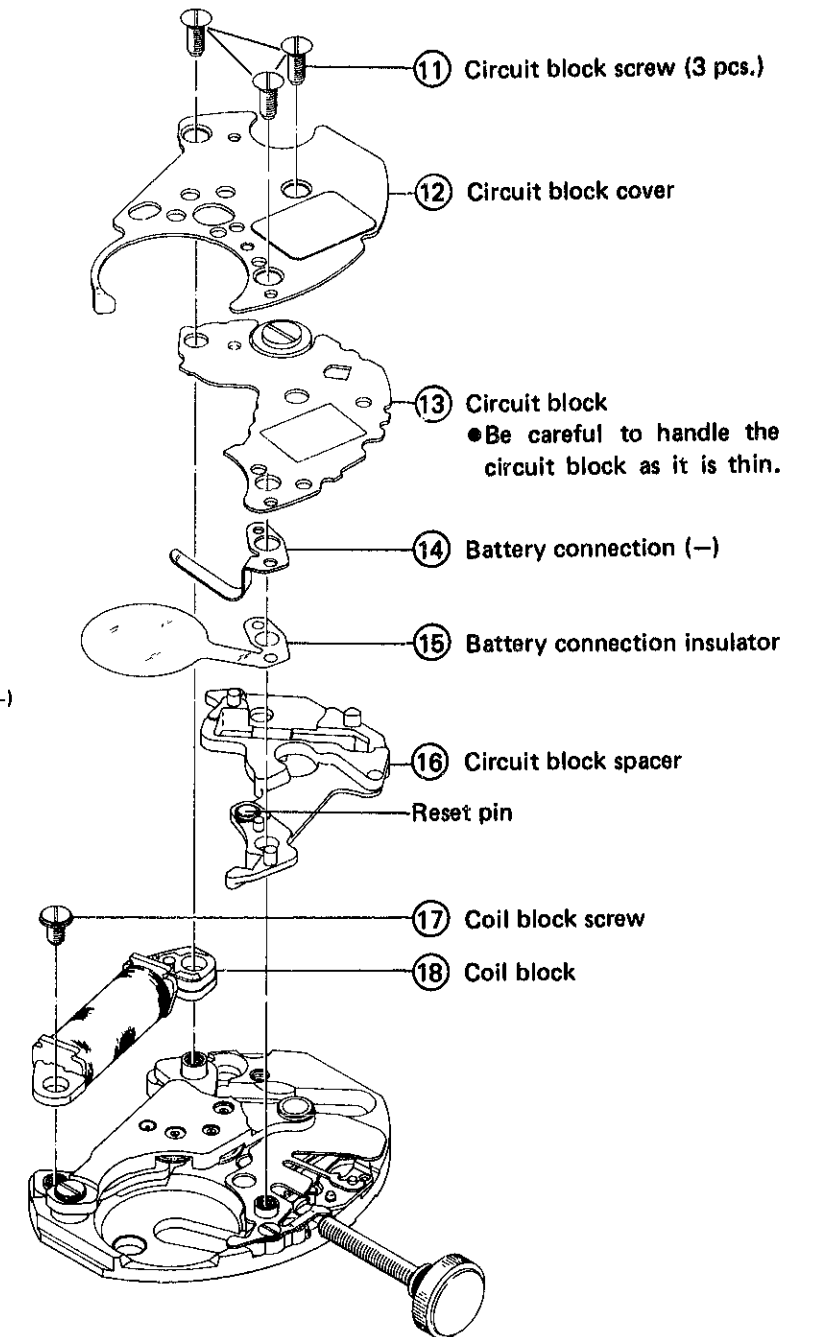

3. Train wheel bridge screw ~ Clutch wheel

● Setting position of the gear train [For 3 hand watches]

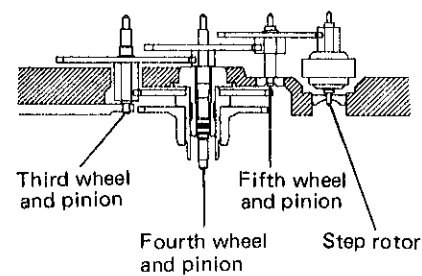
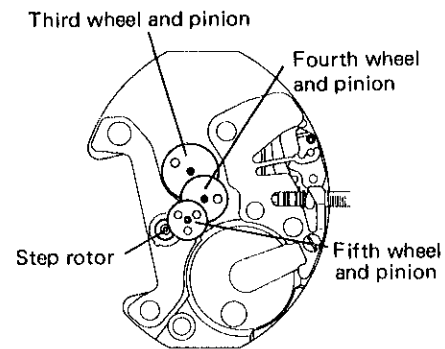

[For 2 hand watches]

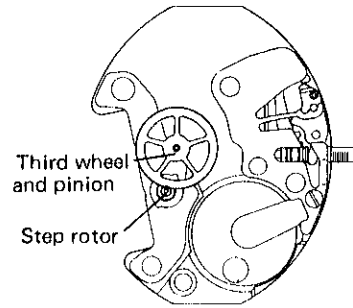

Setting position of ③③ ~ ②⑧

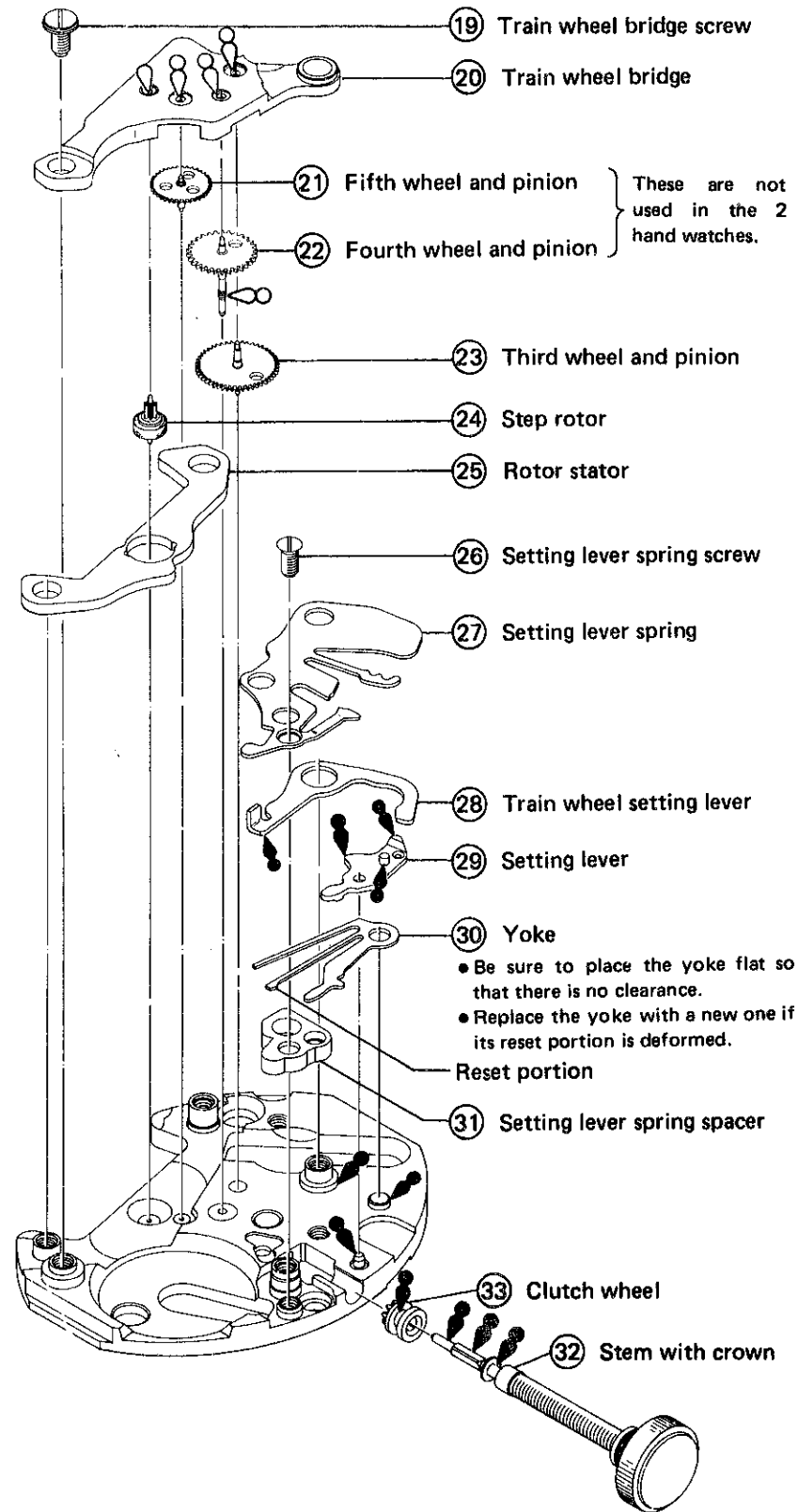
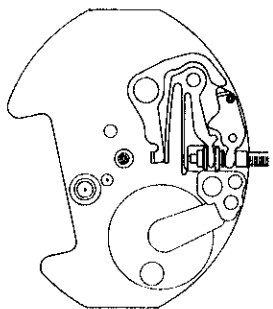

IV. CHECKING AND ADJUSTMENT

- The explanation here is for the particular points of Cal. 2C20A and 2C21A.
Refer to the "TECHNICAL GUIDE, GENERAL INSTRUCTION" for SEIKO Analogue Quartz for details.

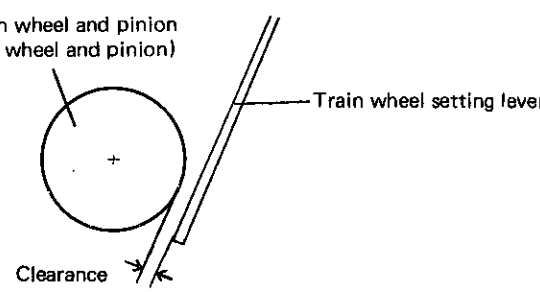
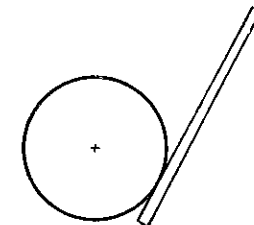
Procedure	
CHECK OUTPUT SIGNAL	<p>Result:</p> <p>[For 3 hand watches] Normal: Input indicator blinks every second. Defective: Input indicator does not blink every second.</p> <p>[For 2 hand watches] Normal: Input indicator blinks every 10 seconds. Defective: Input indicator does not blink every 10 seconds.</p>
CHECK BATTERY VOLTAGE	<p>Use the volt-ohm-meter. Range to be used: DC 3V</p> <p>Result:</p> <p>Normal: More than 1.5V Defective: Less than 1.5V Replace the battery with a new one.</p>
CHECK RESET AND TRAIN WHEEL SETTING CONDITION	<p>Prior to checking, assemble up to the train wheel bridge screw.</p> <p>(1) Check train wheel setting condition.</p> <p>Check the clearance between the train wheel setting lever and the fourth wheel and pinion. (For 2 hand watches, check the clearance between the train wheel setting lever and the third wheel and pinion.)</p> <ul style="list-style-type: none"> ● With the crown at the normal position <p>Fourth wheel and pinion (Third wheel and pinion)</p>  <p>Result:</p> <p>Normal: Clearance Defective: No clearance Replace the train wheel setting lever with a new one.</p> ● With the crown at the first click position  <p>Result:</p> <p>Normal: No clearance Defective: Clearance Replace the train wheel setting lever with a new one.</p>

Procedure

(2) Check reset condition.

Reset condition can be confirmed by checking output signal with a battery installed.

● With the crown at the normal position

Result:

[For 2 hand watches]

Normal: Input indicator blinks every 20 seconds.

Defective: Input indicator does not blink every 20 seconds.

[For 3 hand watches]

Normal: Input indicator blinks every second.

Defective: Input indicator does not blink every second.

Replace the train wheel setting lever with a new one.

● With the crown at the first click position

Result:

[For 2 hand watches]

Normal: Input indicator does not blink every 20 seconds.

Defective: Input indicator blinks every 20 seconds.

[For 3 hand watches]

Normal: Input indicator does not blink every second.

Defective: Input indicator blinks every second.

Replace the train wheel setting lever with a new one.

CHECK BATTERY CONDUCTIVITY

Check to see whether the battery voltage is transmitted to the circuit block.

CHECK CONDUCTIVITY OF CIRCUIT BLOCK

Check for any short circuit or defective conductivity of the conductive part of the circuit block.

CHECK COIL BLOCK

Check for any broken wire or short circuit of the coil block. Use the volt-ohm-meter, and be sure to make a zero-ohm adjustment. Range to be used: OHMS x 100

Result:

[For 2 hand watches]

Normal: 1.7KΩ ~ 2.3KΩ

Defective — Less than 1.7KΩ (Short circuit) More than 2.3KΩ (Broken wire)

Procedure

[For 3 hand watches]

Normal: 2.8KΩ ~ 3.4KΩ

Defective — Less than 2.8KΩ (Short circuit) More than 3.4KΩ (Broken wire)

Replace the coil block with a new one.

CHECK GEAR TRAIN MECHANISM

Check alignment and play in the step rotor and in the wheels, and also check to see whether the gear train is contaminated with dust or lint and whether it is properly lubricated.

CHECK SETTING MECHANISM

Check alignment and play in the wheels, and also check to see whether the setting mechanism is contaminated with dust or lint and whether it is properly lubricated.

CHECK CURRENT CONSUMPTION

- Do not check current consumption under an incandescent lamp since strong light may cause a watch to consume excess current.
● Be sure to protect the movement from light with a black cloth, etc. while measuring.

Use the Digital Multi-Tester S-840A.

Set the A-V switch of the multi-adapter to the "A" position and the mode switch of the tester to the "μA". The tester's value-averaging calculation function automatically takes average of a maximum and a minimum current consumption values.

Read the figure displayed to attain the averaged value.

Check current consumption for the whole of the movement.

Place the battery on the train wheel bridge, and then check current consumption.

Probe red Battery connection (-)
Probe black Battery (-) surface

Result:

[For 2 hand watches]

Normal: Less than 0.5μA
Defective: More than 0.5μA

[For 3 hand watches]

Normal: Less than 0.8μA
Defective: More than 0.8μA

*How to find defects when the current consumption is more than 0.5μA for 2 hand watches and more than 0.8μA for 3 hand watches.

Check current consumption for the circuit block alone with the crown at the first click position.

Result:

[For 2 hand watches]

Normal (Circuit block): Less than 0.25μA
Check the gear train mechanism.

Defective (Circuit block): More than 0.25μA
Replace the circuit block with a new one.

Procedure

[For 3 hand watches]

Normal (Circuit block): Less than $0.3\mu A$
Check the gear train mechanism.

Defective (Circuit block): More than $0.3\mu A$
Replace the circuit block with a new one.

In case of using a volt-ohm-meter, calculate the current consumption as below:

As a 2 hand watch moves at 20 second intervals, the pointer of the tester swings once every 20 seconds when measuring the current consumption.

When the (+) and (-) probes of the tester are applied to a watch, the pointer swings slightly, indicating the current is flowing in the IC. After 20 seconds, the motor driving current flows besides the current flowing in the IC and the pointer swings again.

The current consumption is calculated as follows:

Example

IC current = $0.25\mu A$

IC current + Motor driving current = $0.85\mu A$

The current necessary for driving a motor alone is $0.6\mu A$.

This value, however, shows the current consumption for 20 seconds.

Therefore, it must be converted into the current consumption per second.

Reduce the value $0.6\mu A$ to $1/20$, and the current consumption necessary only for the step motor is about $0.03\mu A$.

Accordingly the value of current consumption by this watch is:

$0.25\mu A + 0.03\mu A = 0.28\mu A$

CHECK ACCURACY

Use the electromagnetic detection microphone.

Range to be used:

For 2 hand watches: Use 10-second gate.

For 3 hand watches: Any gate is available.

CHECK BATTERY LIFE INDICATOR

Check to see if the second hand moves at 2-second intervals when the output voltage is set on $1.30V \sim 1.48V$.

CHECK WATER RESISTANCE

CHECK APPEARANCE AND FUNCTIONING

All procedures of Disassembling, Reassembling, Lubricating, Checking and Adjustment are completed.

SEIKO QUARTZ TECHNICAL GUIDE
Cal. 2C21A with Components

The explanation here is only for a map meter (curvimeter) unit and compass unit which the watch of Cal. 2C21A provides.

As for the watch complete, please refer to the "TECHNICAL GUIDE for Cal. 2C21A".

Map meter unit (Parts code: GA990140)

Distance indication	A pointer (indicates a real distance by rolling the pointer drive wheel on a map.)
Scale	1 graduation = 100 m (in case of a map of a scale of 1 : 50,000)

Compass unit (Parts code: GA990150)

Accuracy	Error of direction : Less than 1° (Less than 5° when the compass is attached onto the unit holder and affected by magnetization of the unit holder.)
----------	---

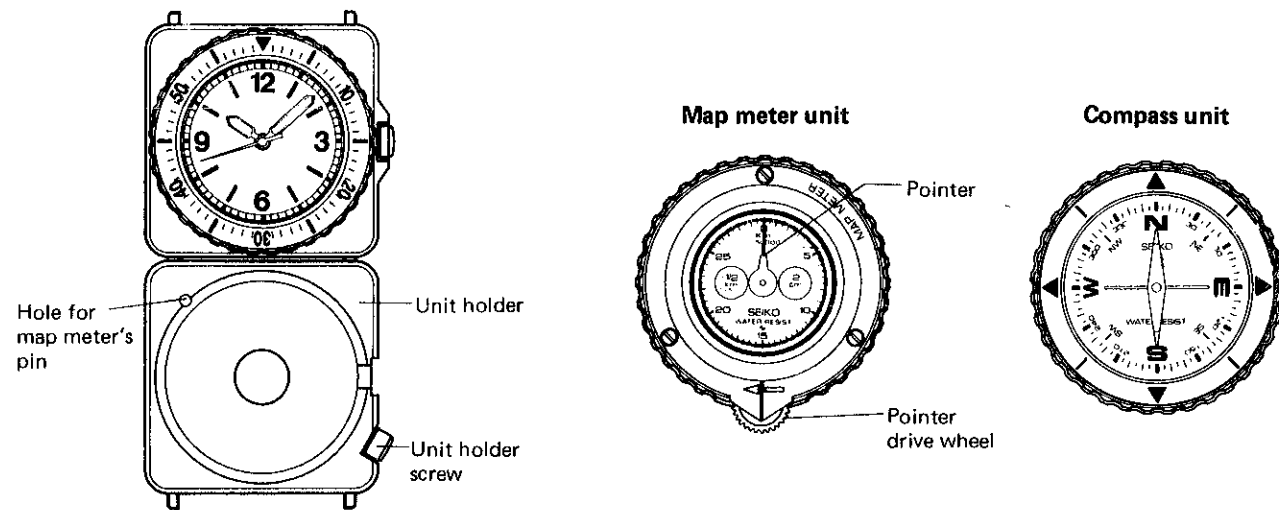

How to remove the unit

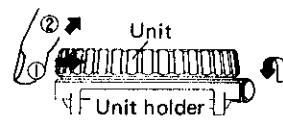

1. Turn the unit holder screw counterclockwise until it stops.
2. While pressing the unit with a finger in the direction of ①, lift it up in the direction of ② to remove it as shown in the illustration on the left.

How to attach the unit

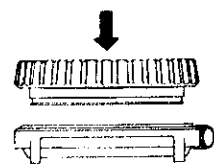

1. First, check that the unit holder screw is loosened.
2. Press the unit down onto the unit holder horizontally.
 - The map meter is provided with a setting position guide pin on its 6 o'clock position.
 - Set the pin into the hole of the unit holder.
3. Turn the unit holder screw clockwise to fix the unit.

DISASSEMBLING, REASSEMBLING, AND LUBRICATING OF THE MAP METER (CURVIMETER) UNIT

- If there arises difficulty with the rotation of the driving wheel, replace the whole unit with a new one.

Disassembling procedures Figs.: ① → ⑤

Reassembling procedures Figs.: ⑤ → ①

Lubricating

Type of oil:

- SEIKO Watch Oil S-6
- Normal quantity

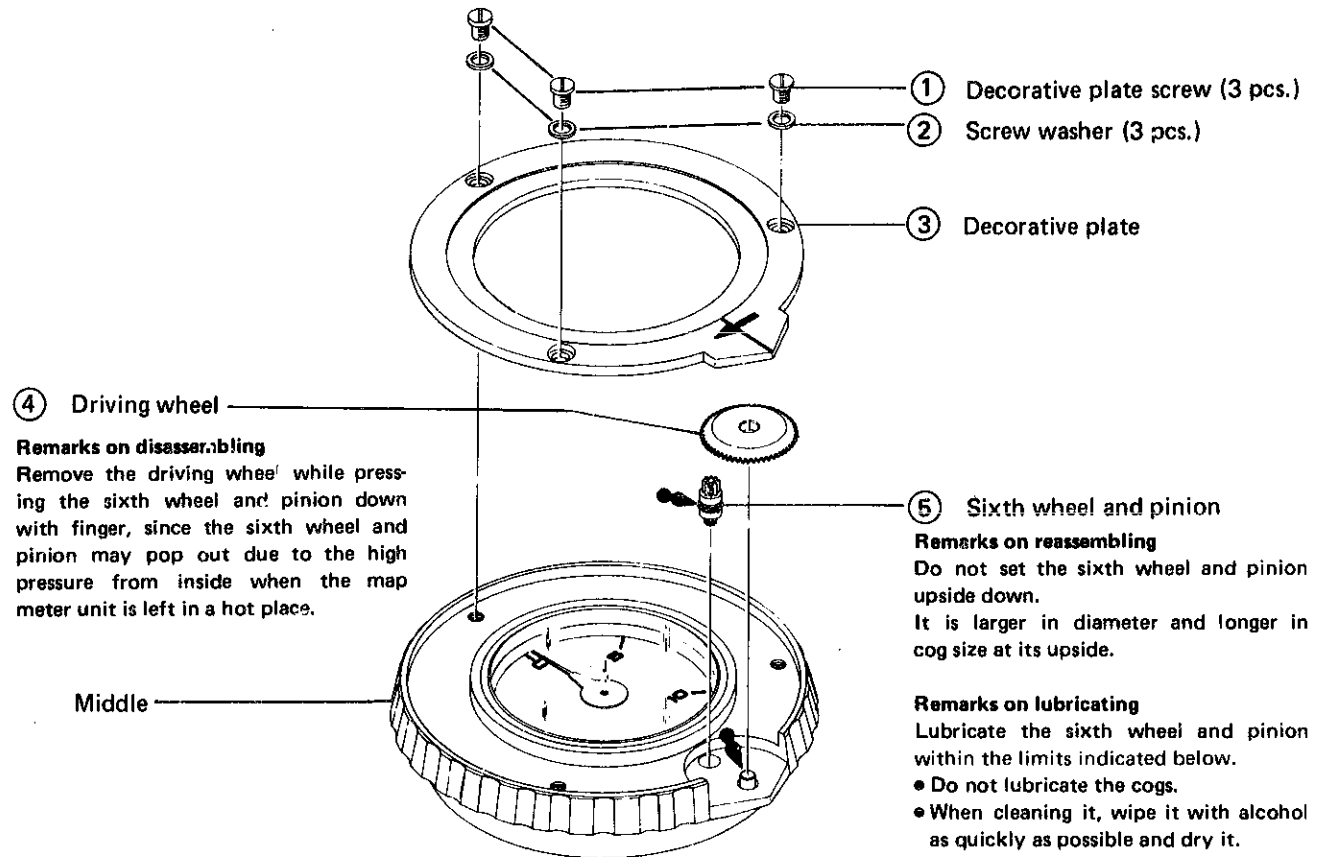

Remarks on disassembling
 Remove the driving wheel while pressing the sixth wheel and pinion down with finger, since the sixth wheel and pinion may pop out due to the high pressure from inside when the map meter unit is left in a hot place.

Remarks on reassembling
 Do not set the sixth wheel and pinion upside down. It is larger in diameter and longer in cog size at its upside.

Remarks on lubricating
 Lubricate the sixth wheel and pinion within the limits indicated below.
 • Do not lubricate the cogs.
 • When cleaning it, wipe it with alcohol as quickly as possible and dry it.

