

SEIKO

QUARTZ

Cal. 16A

PARTS LIST

Calibre No. 16A	Jewels 5j	Style Name
----------------------------------	----------------------------	-------------------



Characteristics

Casing diameter : 15.15 × 13.00 mm
 Maximum height : 3.95 mm
 Frequency of quartz crystal oscillator : 32,768 Hz
 (Hz=Hertz Cycle per second)
 Driving system : Step motor system (2 poles)
 Regulation system : Trimmer condenser



121 160



220 160



☆ 225 160



231 160



241 160



261 160



271 160



281 160



282 160



291 160



351 160



383 160



384 160



385 160



386 160



390 160



391 160



491 160



493 160



701 160



768 160



4001 160



4002 160



4146 004



4216 160



4225 160



4239 160



4242 161



4270 160



SEIKO SB-D1

●	●	▽	T	▽
011 541	011 550	012 107	012 146	012 777



2/1

Calibre No. 16A	Jewels 5j	Style Name
---------------------------	---------------------	------------

PART NO.	PART NAME	PART NO.	PART NAME
121 160	Train-wheel bridge	4239 160	Rotor stator
220 160	Great wheel (with friction pinion)	4242 161	Plus terminal of battery connection
☆ 225 160	Cannon pinion (1.52 mm)	4270 160	Battery connection
☆225 161	Cannon pinion (1.62 mm)	011 541	Upper hole jewel for step rotor
☆225 162	Cannon pinion (2.02 mm)	011 541	Lower hole jewel for step rotor
231 160	Third wheel & pinion	011 550	Upper hole jewel for third wheel
241 160	Fourth wheel & pinion	011 550	Upper hole jewel for fourth wheel
261 160	Minute wheel	011 550	Upper hole jewel for fifth wheel
☆ 271 160	Hour wheel (0.90 mm, Silver)	012 107	Dial screw
☆271 161	Hour wheel (1.00 mm, Gold)	012 146	Circuit block screw
☆271 162	Hour wheel (1.40 mm, Silver)	012 146	Screw for holding spring for battery
281 160	Setting wheel	012 146	Screw for plus terminal of battery connection
282 160	Clutch wheel	012 146	Train-wheel bridge screw
291 160	Intermediate setting wheel	012 777	Setting lever spring screw
351 160	Winding stem	SEIKO SB-D1	SEIKO genuine silver oxide battery
383 160	Setting lever	U.C.C.384 }	Substitutive battery
384 160	Yoke (Clutch lever)	U.C.C.392 }	
385 160	Yoke spring (Clutch lever spring)		
386 160	Setting lever spring		
390 160	Setting lever axle		
391 160	Second-setting lever		
491 160	Dial washer		
493 160	Hour wheel ring (0.03 mm thickness)		
493 161	Hour wheel ring (0.05 mm thickness)		
493 162	Hour wheel ring (0.10 mm thickness)		
701 160	Fifth wheel & pinion		
768 160	Setting lever axle ring		
4001 160	Circuit block		
4002 160	Coil block		
4146 004	Step rotor		
4216 160	Insulator for battery		
4225 160	Holding spring for battery		

Remarks :

There are two different types of the following parts.
Combination :

Type	Cannon pinion	Hour wheel
a	 ☆225 160 (1.52 mm)	☆271 160 (0.90 mm, Silver)
b	 ☆225 161 (1.62 mm)	☆271 161 (1.00 mm, Gold)
c	 ☆225 162 (2.02 mm)	☆271 162 (1.40 mm, Silver)

☆⇔ Please see remarks.

Part numbers in light letters are not shown in photos.

TECHNICAL GUIDE

SEIKO
QUARTZ

CAL. 16A

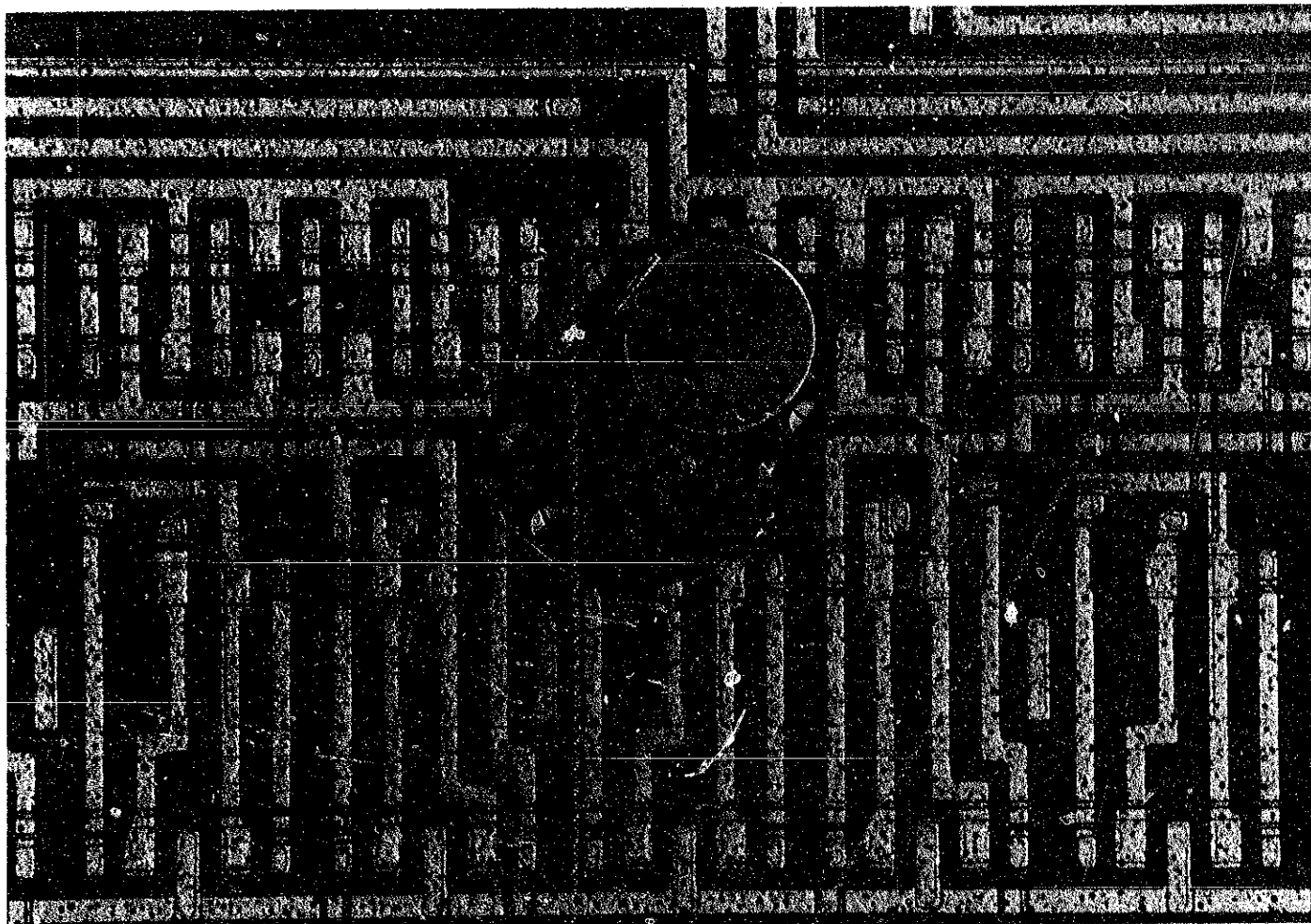

CONTENTS

I. SPECIFICATIONS AND FEATURES	1
1. Specifications	1
2. Features	1
II. GEAR TRAIN MECHANISM	2
III. HOW TO SET THE TIME	2
IV. AFTER-SALE SERVICING INSTRUMENTS AND MATERIALS	2
V. DISASSEMBLING, REASSEMBLING, LUBRICATING AND CLEANING	3
1. Case	3
2. Electronic circuit and gear train mechanism	4
3. Setting mechanism	6
4. Cleaning	8
VI. CHECKING AND ADJUSTMENT	9
1. Guide table for Checking and Adjustment	9
2. Procedures for Checking and Adjustment	10
A. Check output signal	10
B. Check battery voltage	10
C. Check battery conductivity	10
D. Check circuit block conductivity	12
E. Check reset condition	12
F. Check coil block	14
G. Check output signal	14
H. Check second setting lever condition	14
I. Check accuracy	14
Time accuracy adjustment method	16
Measuring current consumption	16

SEIKO Quartz Calibre 16A

The SEIKO Quartz Cal. 16A is a thin and compact quartz crystal oscillator watch providing easy after-sale servicing, which has been made possible through SEIKO's advanced manufacturing techniques and the possible complete electronic systems available today.

Calibre 16A

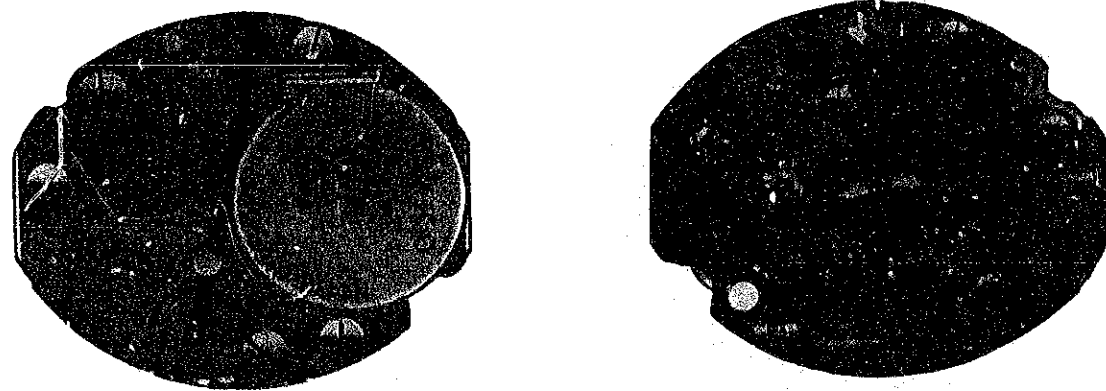

Movement

Actual size



I. SPECIFICATIONS AND FEATURES

1. Specifications

Item	Calibre No. 16A
Time indication	2 hands (hour & minute)
Additional mechanism	Electronic circuit reset switch
Crystal oscillator	32,768 Hz (Hz = Hertz . . . cycles per second)
Loss/gain	Loss/gain at normal temperature Monthly rate: less than 15 seconds (Annual rate: less than 3 minutes)
Casing diameter	15.1 mm x 13.0 mm
Height	3.9 mm
Operational temperature range	-10°C ~ +60°C (14°F ~ 140°F)
Driving system	Step motor system (2 poles)
Regulation system	Trimmer condenser
Battery power	SEIKO genuine silver oxide battery SB-D1 Battery life is over 2 years. Voltage 1.5 V
Jewel	5 jewels

Remarks: Substitute battery for servicing . . . U.C.C. 392

2. Features

This ladies' dress watch is artistically produced of a craftsmanship which is the mode of today. Crystallized in its microcosm, like a tiny shell of about 0.6 cm³, are modules of a quartz crystal oscillator, coil block and other functional parts to form a timeless gem which takes on the same touch of elegance and profile as the already proven mechanical watch Cal. 11 (ZW series).

II. GEAR TRAIN MECHANISM

- (1) Electric signal is transmitted from the circuit block into the coil block once every 2.5 seconds and the rotor stator becomes magnetized.
- (2) When the rotor stator becomes magnetized, the N and S poles of the rotor stator and the N and S poles of the step rotor alternately repel and attract causing the step rotor to rotate in 180° increments once every 2.5 seconds.
- (3) Rotation of the step rotor is transmitted to the gear train to move the hour and minute hands once every 2.5 seconds.

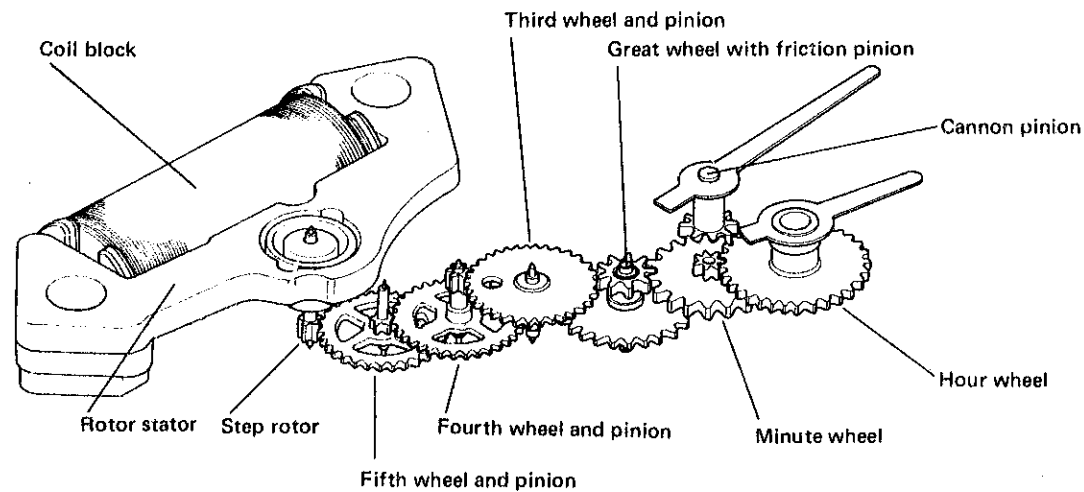

III. HOW TO SET THE TIME

As the special gear train is incorporated with the setting mechanism, it is requested to advance the minute hand from 5 to 10 minutes ahead and turn it back to set the correct time.

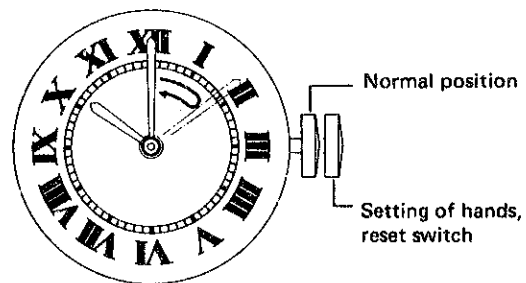

IV. AFTER-SALE SERVICING INSTRUMENTS AND MATERIALS

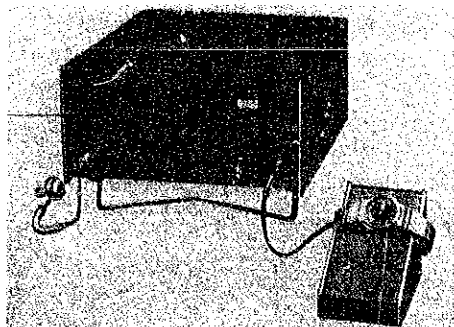

Quartz tester, QT-10

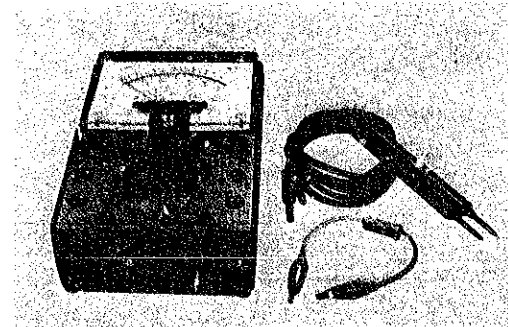

Volt-ohm-meter and condenser kit



Movement holder, S-664

V. DISASSEMBLING, REASSEMBLING, LUBRICATING AND CLEANING

• Disassembling and reassembling

Disassembling procedures Figs.: ① ~ ⑩

Reassembling procedures Figs.: ⑩ ~ ①

• Lubricating

Type of oil: ● Moebius A
 ○ SEIKO Watch Oil S-6

Oil quantity: ○ Liberal quantity
 ○ Normal quantity
 ○ Extremely small quantity

1. Case

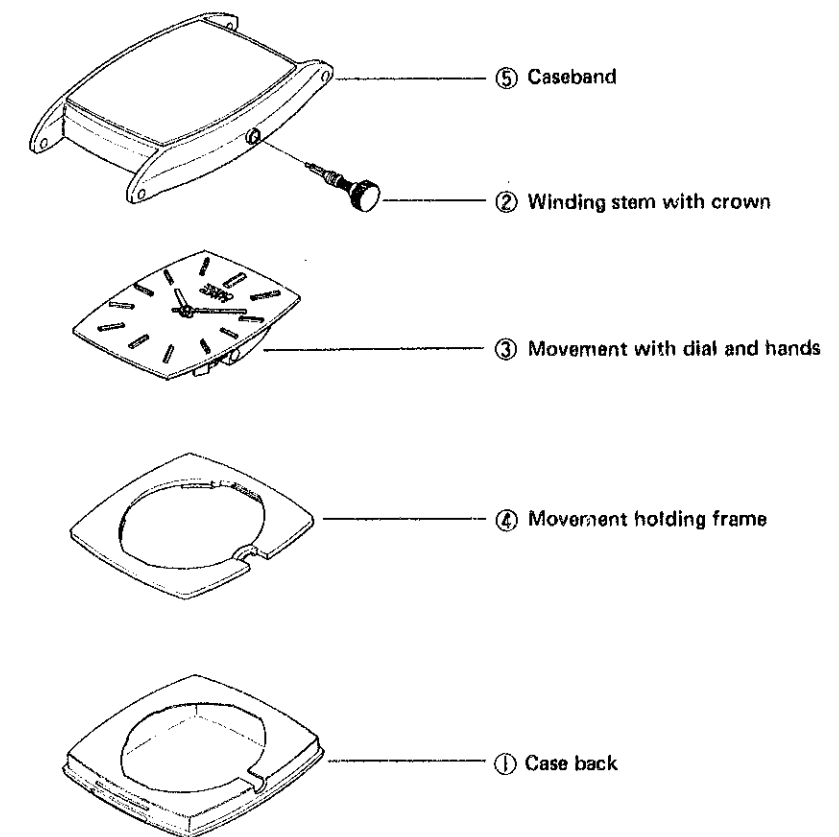

2. Electronic circuit and gear train mechanism

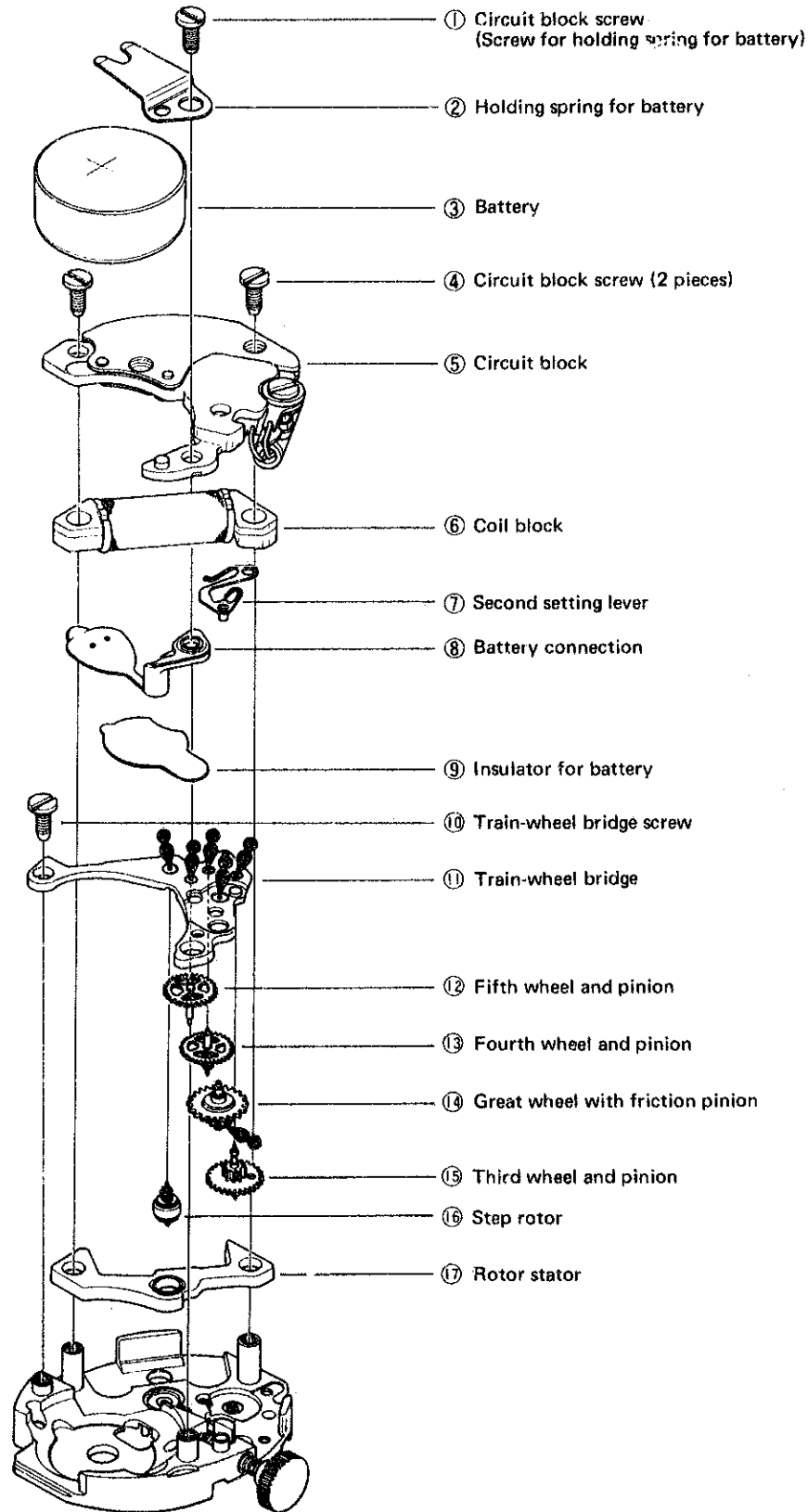

REMARKS FOR DISASSEMBLING AND REASSEMBLING

- When the holding spring for battery is used.

- When the plus terminal of battery connection is used. Adjust the plus terminal of battery connection toward the arrow marked direction (Inner side) for holding the battery securely and tighten the screw.

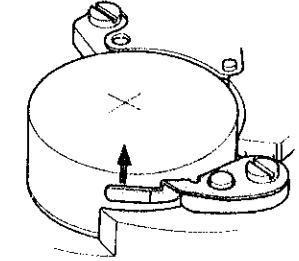
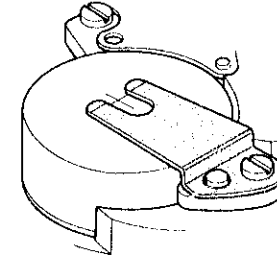

- How to handle the coil block ⑥

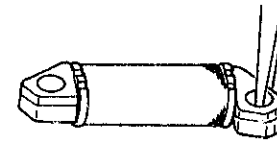

Hold the coil block by the hole with tweezers.

- Position of the second setting lever ⑦

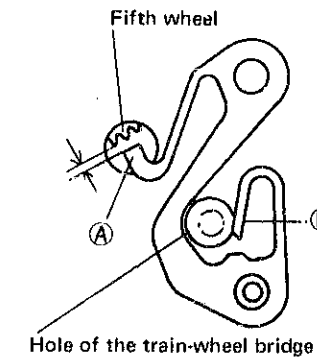
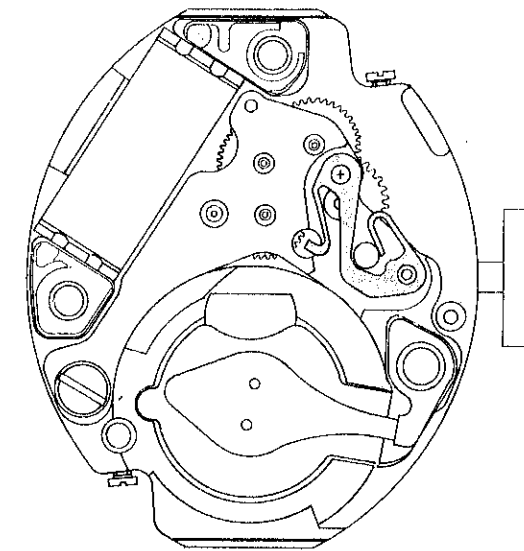

■ Crown position: Normal

Check to see that there is clearance between the second setting lever (A) and the fifth wheel and pinion and that the second setting lever (B) is positioned at the side of the hole of the train-wheel bridge.

■ Crown position: First click

Check to see that the second setting lever (A) touches the fifth wheel and pinion, and that the second setting lever (B) is now positioned on the inside the hole of the train-wheel bridge. As the reset pin (part of the circuit block) is inside the hole of the train-wheel bridge, it will touch the second setting lever if it is located inside the second setting lever as shown in illustration.

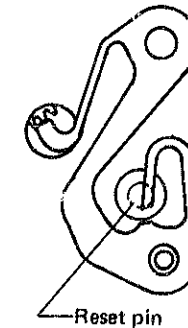

Disassemble and reassemble the second setting lever with the crown at the normal position.

- Handling of great wheel with friction pinion ⑭

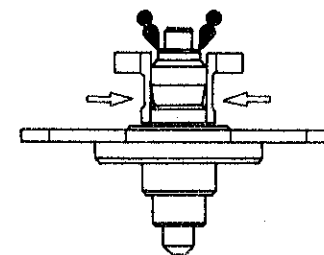

- Be sure to lubricate as shown in the illustration.
- The great wheel and friction pinion are frictionally fixed together at arrow-marked position. Do not disassemble them.

3. Setting mechanism

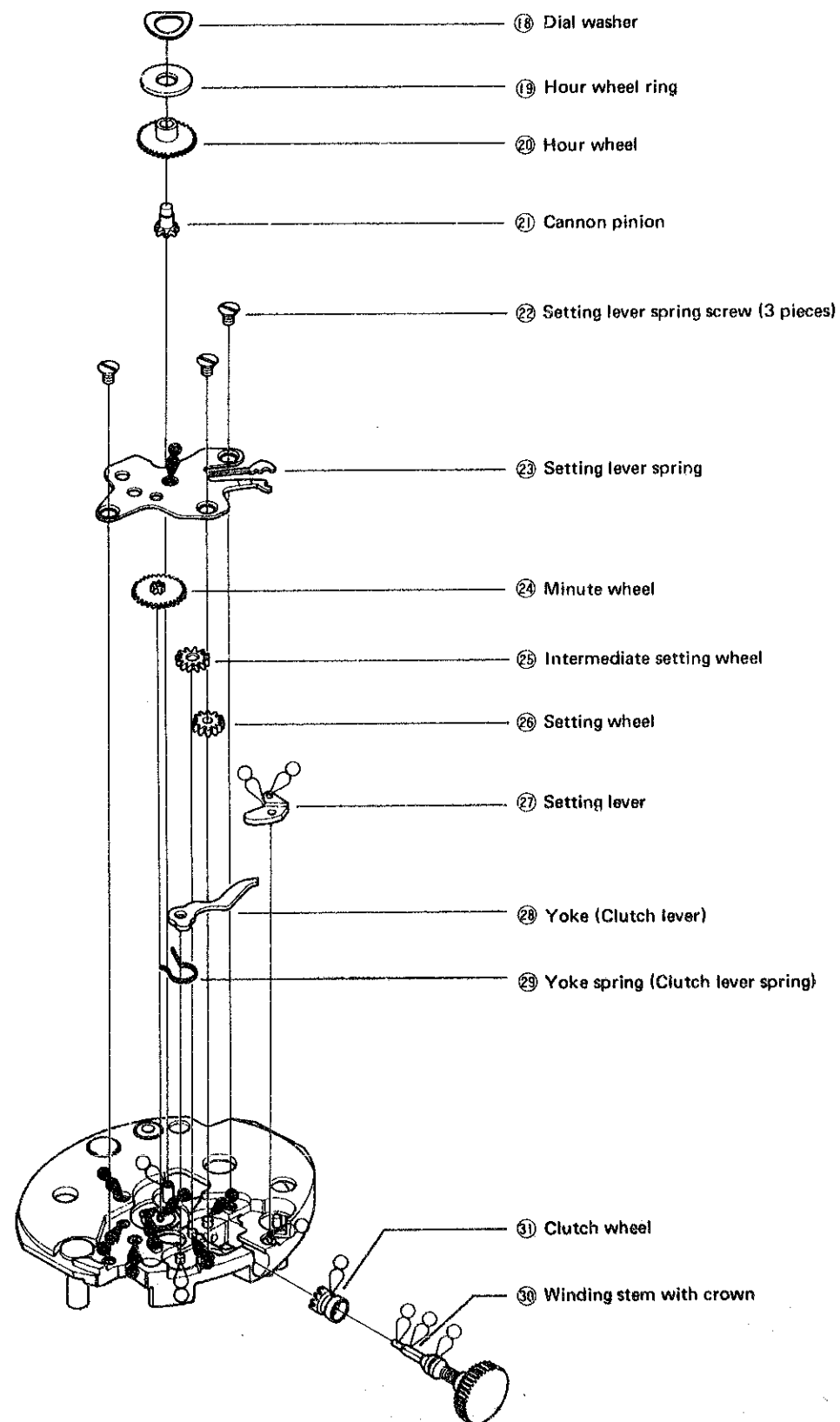

REMARKS FOR DISASSEMBLING AND REASSEMBLING

- Dial washer ⑱
Be careful not to change the original shape of the dial washer.
- Hour wheel ring ⑲
It is used for adjusting the play of the hour wheel but some models are not provided with the hour wheel ring.
- How to assemble the setting lever spring ⑳
Tighten the arrow-marked screw first.

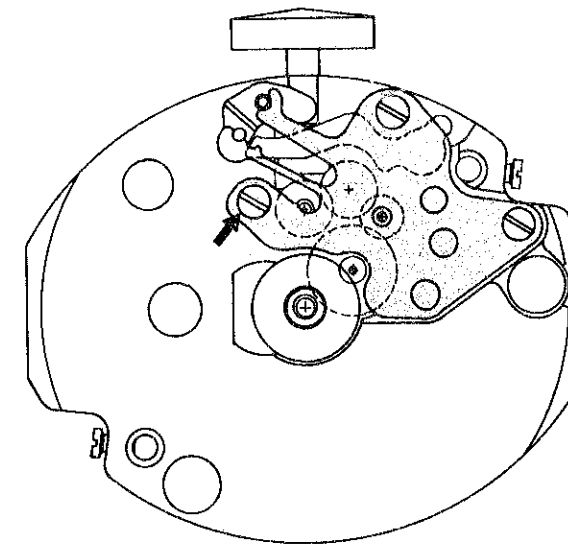

- Difference between the intermediate setting wheel and the setting wheel ㉕ ㉖
The setting wheel and intermediate setting wheel are almost the same in shape, but their thickness is different.

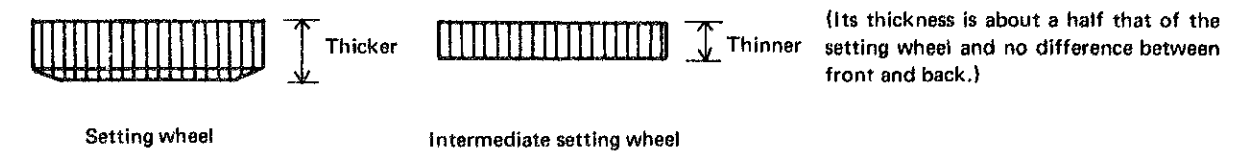

- How to assemble the yoke and the yoke spring ㉘ ㉙





Hook the yoke spring on the pin on the reverse of the yoke as illustrated in the left.

4. Cleaning

Since several special parts (electronic parts, etc.) used in the SEIKO Quartz 16A differ from conventional mechanical watches, use the following cleaning methods when cleaning.

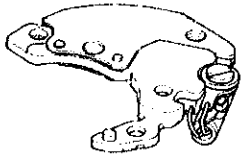
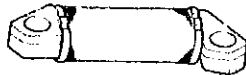
CLEANING METHOD

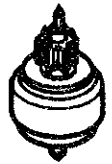
Name of parts	Cleaning	Drying	Solution	Remarks
Circuit block  Coil block 	DO NOT CLEAN			Conductive portion <u>ONLY</u> may be cleaned with a cloth moistened with benzine or alcohol. Dry in <u>COOL</u> air.
Rotor stator  Step rotor 	Rinse or gently scrub with a brush	Cool air	Benzine	Be careful not to bend the rotor stator. Since the step rotor is magnet, use a clean solution. Any foreign matter which cannot be removed by cleaning should be removed with adhesive tape or Rodico.
Plastic parts	Rinse or scrub with a brush	Cool air	Benzine or alcohol	
Parts other than the above	Clean with cleaner, rinse or gently scrub with a brush	Cool or hot air	Benzine or trichloroethylene	

VI. CHECKING AND ADJUSTMENT

1. Guide Table for Checking and Adjustment

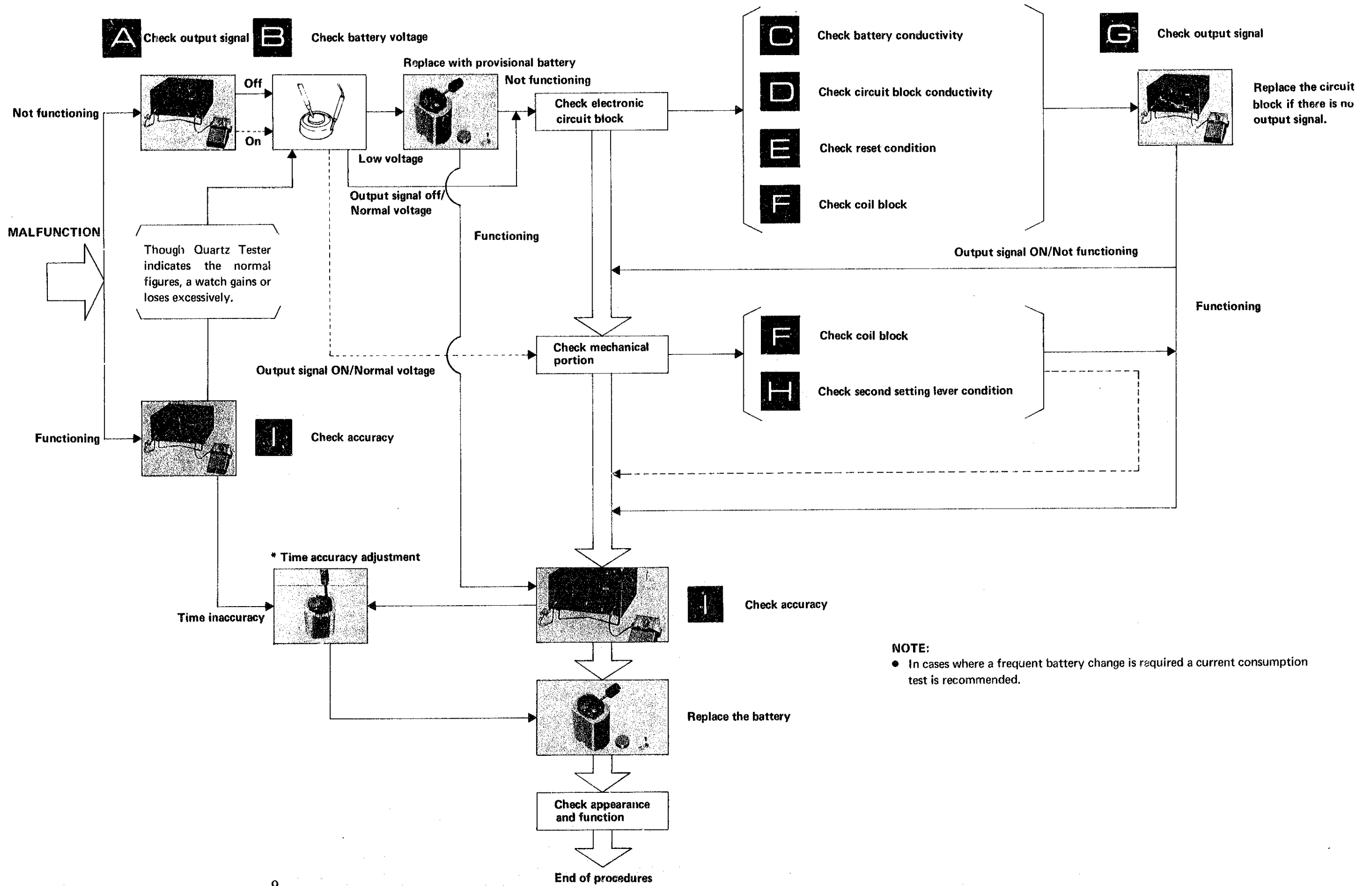

NOTE:
 • In cases where a frequent battery change is required a current consumption test is recommended.

2. Procedures for Checking and Adjustment

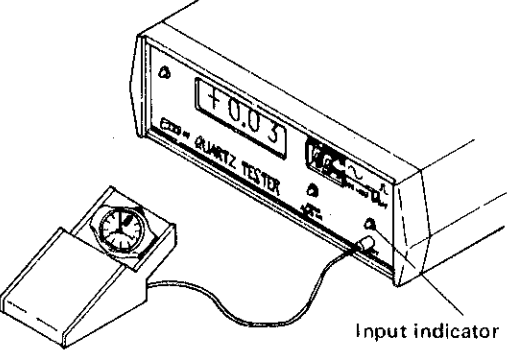
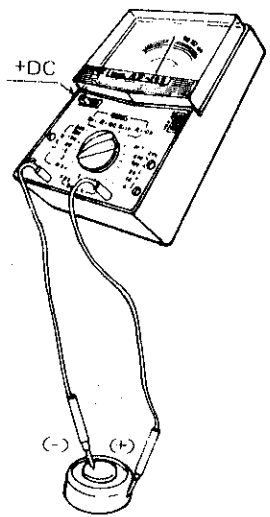
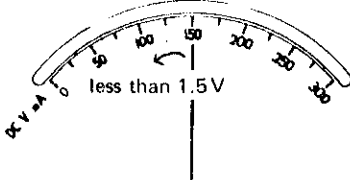
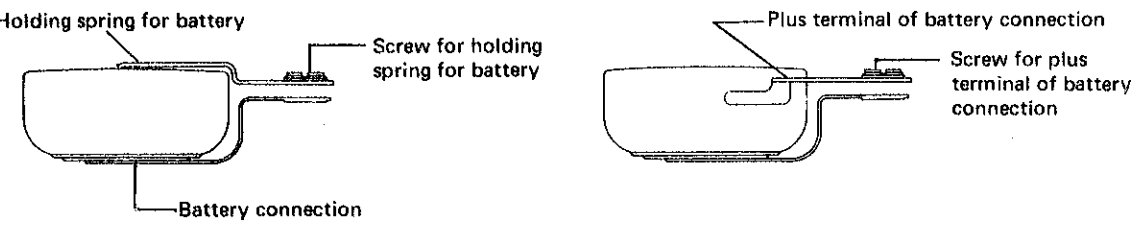
	Procedures	Results	Adjustment and repair
<p style="writing-mode: vertical-rl; transform: rotate(180deg);">CHECK OUTPUT SIGNAL</p>	<p>Check output signal.</p> <p>1. Set up the Quartz Tester. As it is a 2.5-second stepping, turn the measuring time selection switch to "10 second" position.</p> <p>2. Checking Check for output signal (Blinking input indication light)</p> <p>As the minute hand is a 2.5-second stepping, measurement is not possible except when the measuring time selection switch is at the "10 second" position.</p> 	<p>2.5-second blinking →</p> <p>No 2.5-second blinking →</p>	<p>Proceed to B</p>
<p style="writing-mode: vertical-rl; transform: rotate(180deg);">CHECK BATTERY VOLTAGE</p>	<p>Use the following procedures to check battery voltage.</p> <p>1. Set up the volt-ohm-meter. Range to be used: DC 3 V</p> <p>2. Measuring</p> <ul style="list-style-type: none"> • Probe red (+) Battery surface (+) • Probe black (-) Battery surface (-) 	<p>More than 1.5 V →</p> <p>Less than 1.5 V →</p> 	<p>In procedure A, if 2.5-second blinking is found, check the Mechanical Portion</p> <p>In procedure A, if 2.5-second blinking is NOT found, check the Electronic Circuit Block</p> <p>Replace with a new battery.</p> <ul style="list-style-type: none"> • if a watch operates after battery replacement, proceed to H • if a watch does not operate, check the Electronic Circuit Block
<p style="writing-mode: vertical-rl; transform: rotate(180deg);">CHECK BATTERY CONDUCTIVITY</p>	<p>Use the following procedures to check if the battery current flow to the circuit is normal.</p> <p>1. Check to see if the circuit block screw is loosened.</p> <p>2. Check for any foreign matter on the connecting point of the battery, battery connection, holding spring for battery, and plus terminal of battery connection.</p> 	<p>No loosened screw →</p> <p>Loosened screw →</p> <p>Uncontaminated →</p> <p>Contaminated →</p>	<p>Proceed to C₂</p> <p>Retighten screw.</p> <p>Proceed to D</p> <p>Wipe off carefully.</p>

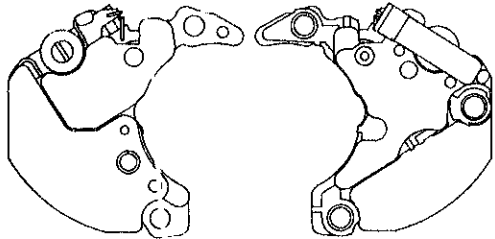
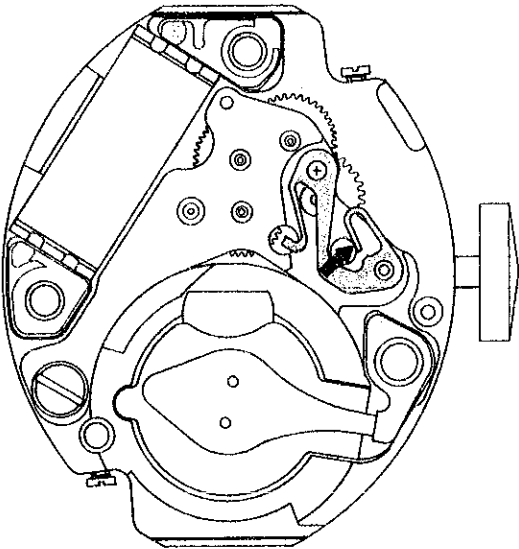
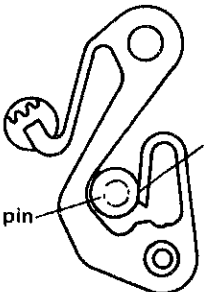
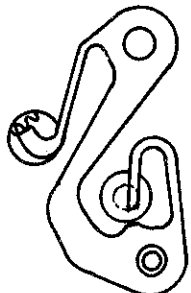
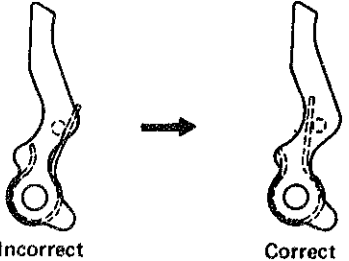
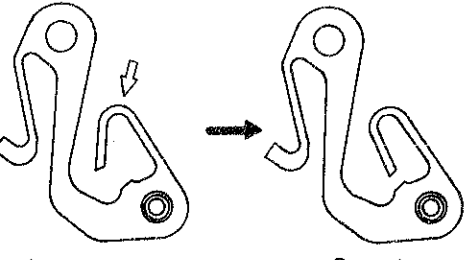
	Procedures		Results	Adjustment and repair
D CHECK CIRCUIT BLOCK CONDUCTIVITY	<p>Check for short circuit and defective contact of the circuit block conducting portion.</p> <ol style="list-style-type: none"> 1. Check for looseness the two (2) screws of the circuit block. 2. Check for disconnection of the soldered portion, short circuit, and foreign matter on the lead pattern of the circuit block.  <p style="text-align: center;">Circuit block</p>		<p>No loosened screw →</p> <p>Loosened screw →</p> <p>No disconnection of the soldered portion, short circuit and foreign matter. →</p> <p>Disconnection of the soldered portion, short circuit and foreign matter. →</p>	<p>Proceed to D₂</p> <p>Retighten screw.</p> <p>Proceed to E</p> <ul style="list-style-type: none"> • Replace the circuit block when there is disconnection of the soldered portion or short circuit. • If contaminated, wipe off foreign matter on the connections.
F CHECK RESET CONDITION	<p>Check the reset condition using the following procedures.</p> <ol style="list-style-type: none"> 1. Check to see if the output signal is off when the crown is pulled out to the first click after assembling the circuit block and the battery. (Place the watch on the microphone of the Quartz Tester, and check if the output signal is off when the crown is pulled out to the first click.) 2. Remove the circuit block and check the position of the second-setting lever (arrow-marked portion).  <p>■ Crown position: Normal</p>  <p>Hole of the train-wheel bridge</p> <p>Reset pin</p> <p>The reset pin assembled with the circuit block is set into this hole.</p> <p>The second setting lever is positioned on the outer circumference of the hole of the train-wheel bridge.</p> <p>■ Crown position: First click</p>  <p>The second setting lever must be positioned within the hole of the train-wheel bridge.</p>		<p>Stops immediately. →</p> <p>Does not stop. →</p> <p>The second-setting lever is positioned properly as shown in the illustrations when the crown is at the normal position and pulled out to the first click position. →</p> <p>The second-setting lever is not positioned properly as shown in the illustrations when the crown is at the normal position and pulled out to the first click position. →</p>	<p>Proceed to F</p> <p>Proceed to E₂</p> <p>Proceed to F</p> <p>These defects are seemed to be caused by the following:</p> <p>(1) The yoke spring is disengaged from the pin on the reverse of yoka</p>  <p>Incorrect → Correct</p> <p>(2) The second setting lever is bent. Adjust the arrow-marked portion of the second setting lever with tweezers.</p>  <p>Incorrect → Correct</p>

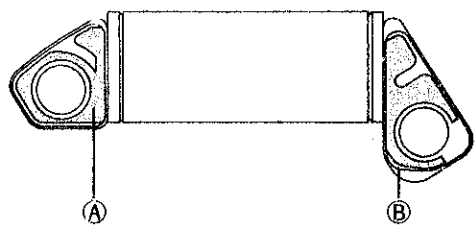
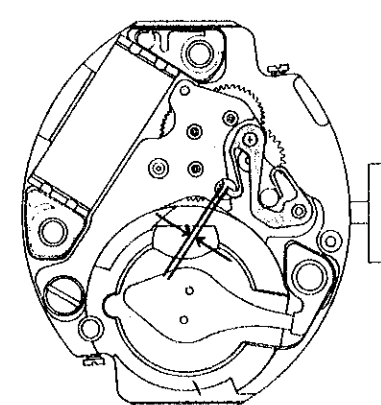
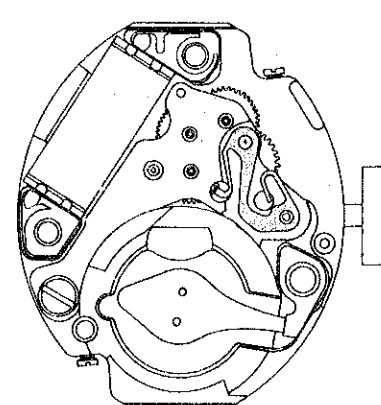
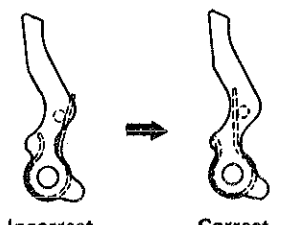
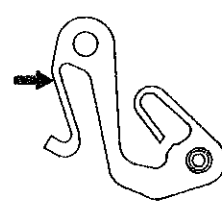
	Procedures		Results	Adjustment and repair
CHECK COIL BLOCK	<p>Check for broken coil wire and short circuit.</p> <p>1. Set up the Volt-ohm-meter. Range to be used: OHMS R x 100</p>  <p>2. Checking Touch the red and black probes to the terminals (A) and (B) of the coil block respectively.</p>		<p>1.5 kΩ ~ 3.5 kΩ →</p> <p>less than 1.5 kΩ (short circuit) → more than 3.5 kΩ (broken wire) →</p>	<p>• If checking the Electronic Circuit Block proceed to G</p> <p>• If checking the Mechanical Portion proceed to H</p> <p>Replace the coil block.</p>
CHECK OUTPUT SIGNAL	<p>Check for output signal.</p> <p>1. Set up the Quartz Tester.</p> <p>2. Checking Follow the same procedures as in A</p>		<p>2.5-second blinking → Not functioning → Functioning →</p> <p>No 2.5-second blinking →</p>	<p>Check the Mechanical Portion</p> <p>Proceed to I</p> <p>Replace the circuit block.</p>
CHECK SECOND SETTING LEVER CONDITION	<p>Check to see if the second setting lever controls the fifth wheel and pinion.</p> <p>Remove the circuit block, check to see if there is clearance between the fifth wheel and pinion and second setting lever.</p> <p>■ Crown position: Normal</p>  <p>There must be clearance between the fifth wheel and pinion and the second setting lever.</p> <p>■ Crown position: First click</p>  <p>The fifth wheel and pinion touches the second setting lever.</p>		<p>Clearance, the crown at the normal position. →</p> <p>No clearance, the crown at the first click position. →</p> <p>No clearance, the crown at the normal position. →</p> <p>Clearance, the crown at the first click position. →</p>	<p>Proceed to I</p> <p>These defects are probably caused by the following:</p> <p>(1) The yoke spring is disengaged from the pin on the reverse of yoke.</p>  <p>Incorrect → Correct</p> <p>(2) The second setting lever is bent. Adjust the arrow-marked portion of the setting lever with tweezers.</p> 
CHECK ACCURACY	<p>Check gain and loss of time.</p> <p>1. Set up the Quartz Tester. Turn the measuring time selection switch to the "10 second" position. (Because of the 2.5-second stepping, the measurement of gain and loss of time is not possible except when the measuring time selection switch is at the "10 second" position.)</p> <p>2. Checking Measure the daily rate.</p>		<p>Normal →</p> <p>Defective →</p>	<p>Replace the battery</p> <p>Adjust time accuracy</p>

Time accuracy is adjusted by turning the trimmer condenser.

- Adjustment should be made after ascertaining by the Quartz Tester whether the watch tends to gain or lose. The watch gains or loses according to the direction in which the trimmer condenser is turned.
- Note for handling of Trimmer condenser
 1. Avoid excessive depressing.
 2. Avoid turning the Trimmer condenser unnecessarily.



In cases where a frequent battery change is required, a current consumption test is recommended. Use the following procedures:

1. Set up the condenser kit ($200 \mu\text{F} \sim 500 \mu\text{F}$) as shown in the photo.
2. Range to be used: DC 6 mA

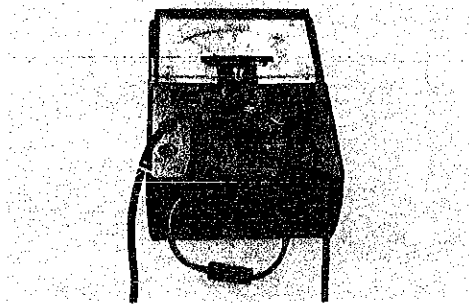

3. Place the battery on the metal part of the circuit block with its plus surface down.
4. Touch the red and black probes as follows.
 - Probe Red (+) Battery connection
 - Probe Black (-) Battery surface (-)

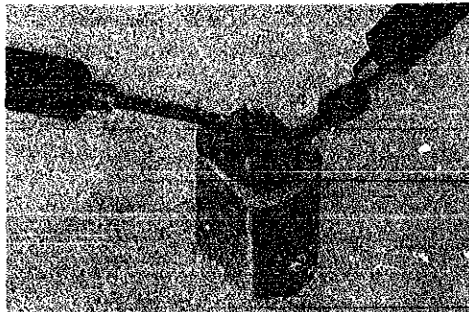

5. When the pointer stabilizes, turn the rotary switch to set the current measuring range at DC 0.03 mA and read the current consumption.

(Note: During the measurement, be careful not to detach the probes from the battery and battery connection.)

If the range of the Volt-ohm-meter is set at DC 0.03 mA for measuring the current consumption of the Calibre 16A and when the probe of the Volt-ohm-meter touches the battery connection and the battery, the current consumption will become higher for a while than usual, because an electric signal from the circuit block is generated in order to offset the reversed backlash of the gear train.

Unless the above procedures (1 ~ 5) are not followed, the pointer of the Volt-ohm-meter may scale out and it is impossible to measure the current consumption.

All procedures of Disassembling and Reassembling, and Checking and Adjustment are completed.